

YAMAHA FM SOUND GENERATOR FB-01

SERVICE MANUAL

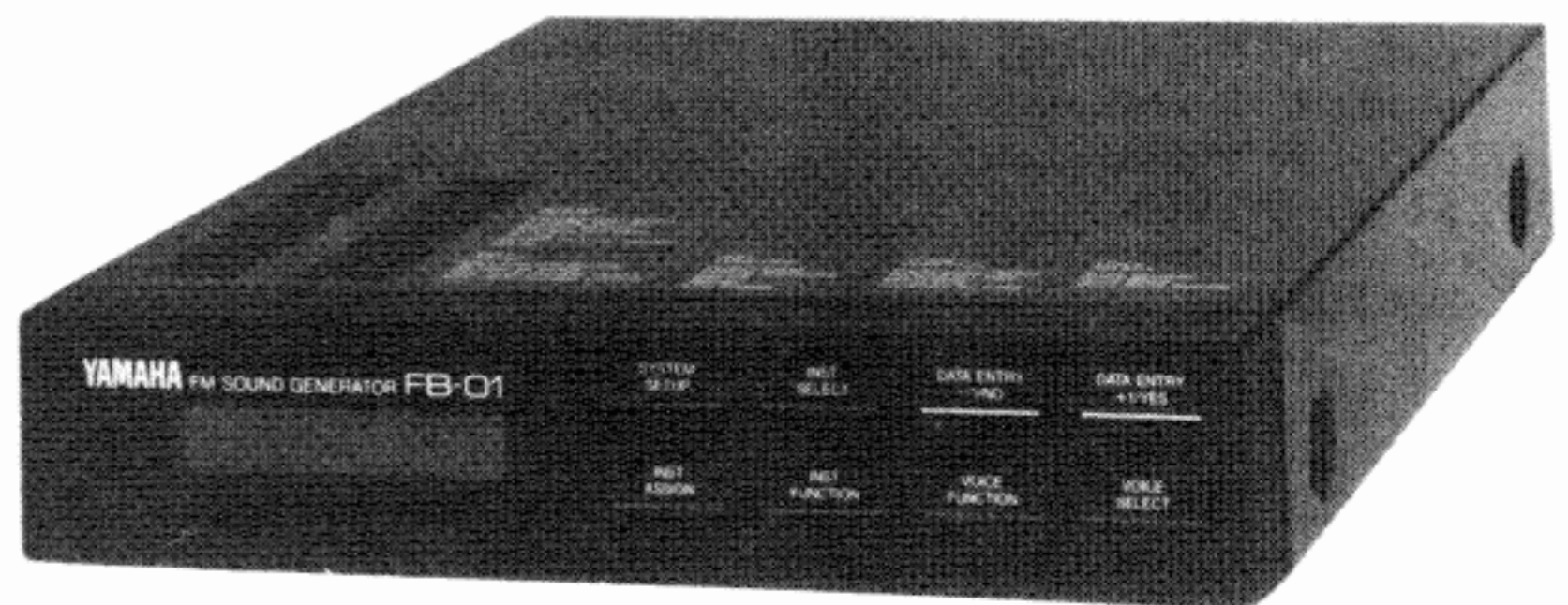

■ CONTENTS

Specifications	2
Functions & Features	3
Circuit Operation	4
FB-01 Memory Map & I/O Port Map	5
Operational Check by Utilizing the Test Program	6
Description on MIDI	10
MIDI Receive Data Format 1 (Channel message, System message)	11
MIDI Receive Data Format 2 (System Exclusive message)	12
Other System messages	14
Parameter List	17
MIDI Transmit Data Format	19
Parts List	



IMPORTANT NOTICE

This manual has been provided for the use of authorized Yamaha Retailers and their service personnel. It has been assumed that basic service procedures inherent to the industry, and more specifically Yamaha Products, are already known and understood by the users, and have therefore not been restated.

WARNING: Failure to follow appropriate service and safety procedures when servicing this product may result in personal injury, destruction of expensive components and failure of the product to perform as specified. For these reasons, we advise all Yamaha product owners that all service required should be performed by an authorized Yamaha Retailer or the appointed service representative.

IMPORTANT: The presentation or sale of this manual to any individual or firm does not constitute authorization, certification, recognition of any applicable technical capabilities, or establish a principle-agent relationship of any form.

The data provided is believed to be accurate and applicable to the unit(s) indicated on the cover. The research, engineering, and service departments of Yamaha are continually striving to improve Yamaha products. Modifications are, therefore, inevitable and changes in specification are subject to change without notice or obligation to retrofit. Should any discrepancy appear to exist, please contact the distributor's Service Division.

WARNING: Static discharges can destroy expensive components. Discharge any static electricity your body may have accumulated by grounding yourself to the ground buss in the unit (heavy gauge black wires connect to this buss).

IMPORTANT: Turn the unit OFF during disassembly and parts replacement. Recheck all work before you apply power to the unit.

This product uses a lithium battery for memory back-up.

WARNING: Lithium batteries are dangerous because they can be exploded by improper handling. Observe the following precautions when handling or replacing lithium batteries.

- Leave lithium battery replacement to qualified service personnel.
- Always replace with batteries of the same type.
- When installing on the PC board, solder using the connection terminals provided on the battery cells. Never solder directly to the cells. Perform the soldering as quickly as possible.
- Never reverse the battery polarities when installing.
- Do not short the batteries.
- Do not attempt to recharge these batteries.
- Do not disassemble the batteries.
- Never heat batteries or throw them into fire.

SPECIFICATIONS

CPU

μ pD70008	AC-6 (equivalent of the Z-80B C-MOS)
CLOCK	6MHz ($\pm 0.5\%$)
WAIT	3 or 4 WAIT cycles are inserted when accessing the LCD
INTERRUPT	Only MODE 1 used (NMI unused)
	INTERRUPT is generated from USART (μ pD71051) & OPP (YM2164)
RESET	POWER ON RESET only

MEMORY

8 x 8 KBIT S-RAM x 2 16 KBYTES (150ns)
 All provided with battery-backup
 32 KBYTES Program ROM (150ns)
 Be sure to use 150ns speed MEMORY to be compatible with the CPU access speed.

SOUND SOURCE

FM sound source utilizes the OPP (YM2164) and the DAC (YM3012)	
CLOCK	4MHz ($\pm 0.2\%$)
Amp.	L-R 2ch
Amplification	9.2dB (1kHz)
Frequency response	10Hz ~ 16kHz (-3dB)
Q	0.72
Residual noise	0.4mV or less (RMS AC voltmeter 4Hz to 500kHz)
Power ON/OFF noise	10mV/3mV (RMS AC voltmeter 4Hz to 500kHz)
L/R gain difference	Within 0.6dB
Output level	-1.7dBm/1kHz (Sine wave 1 tone/ATT 0dB)
Output impedance	1k Ω /1kHz
D/A conversion sample frequency	62.5kHz

MIDI

USART	μ pD71051C
PHOTO COUPLER	PC910
MIDI transfer rate	31.25kHz $\pm 0.1\%$
MIDI THRU DELAY	Leading 200ns (TYP) Trailing 150ns (TYP)
CONNECTOR	DIN 5P x 3 (MIDI-IN, MIDI-THRU, MIDI-OUT)

DISPLAY

LCD	16 characters per 1 line (5 x 7 dots/1 char)
NEGATIVE TYPE	1/16 DUTY
Optimum visual angle:	Vertical direction 20° against horizontal plane Horizontal direction 0° against vertical plane
Visual angle range	: Optimum vision $\pm 20^\circ$ in vertical direction Optimum vision $\pm 30^\circ$ in horizontal direction
BACK LIGHT	24 chip LED (Working current 180mA)
Color	ORANGE
LCD CONTROLLER	HD44780A or equivalent

INPUT SWITCH

Tact SW (Stroke 1mm) x 8	
SW name	DATA BUS
SYSTEM-SETUP	(D0)
INST-SELECT	(D1)
INST-ASSIGN	(D2)
INST-FUNCTION	(D3)
VOICE-FUNCTION	(D4)
VOICE-SEL	(D5)
- 1/No	(D6)
+ 1/Yes	(D7)

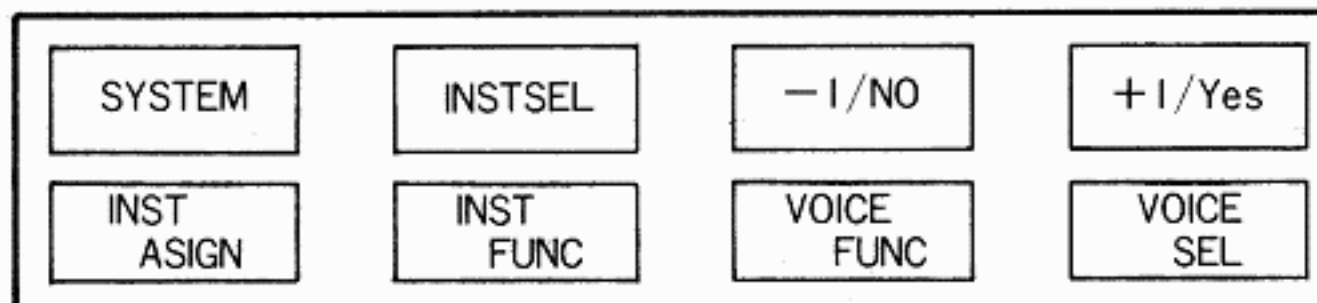

BATTERY BACKUP

Backup battery	lithium battery (160Ah)
Backup period	5 years after Backup SW ON
Backup ON-OFF SW	

POWER SUPPLY

Type	
Series type	+ 3-terminal regulator
Primary side specifications	
$\pm 10\%$ of rated input	50Hz/60Hz
Electricity consumption	9W
Secondary side specifications	
+ 5V (for Digital)	
Accuracy	$\pm 5\%$
Electric current	400mA
$\pm 5V$ (for Analog)	
Accuracy	$\pm 5\%$
Electric current	100mA
GND	+ 5V (for Digital) $\pm 5V$ (for Analog) FLOAT mutually

GENERAL SPECIFICATIONS

Conditions for use

	Product specifications	Catalogue specifications
Temperature	0°C ~ 40°C	0°C ~ 35°C
Humidity	20% ~ 90%	

Temperature for storage

	Product specifications	Catalogue specifications
Temperature	-20°C ~ 60°C	-15°C ~ 60°C
Humidity	10% ~ 90%	10% ~ 90%

Dimensions 218mm(W) x 48mm(H) x 274mm(D)
 Weight

Accessory List: (2) RCA to 1/4 Phone adaptors
 (1) MIDI Cable (1m) ~ 3.2 feet
 (1) Instruction manual
 (1) Warranty Card

FUNCTIONS & FEATURES

(Refer to the instruction manual for handling.)

Instrument

No. of Instruments	Up to 8 instruments can be specified (No.0 to No.7)
No. of tones generated	The FB-01 can generate a maximum of 8 tones or notes. If only one instrument is selected, it can be assigned to have a maximum of 8 notes. However, if two or more instruments are selected, then the total 8 note capability is split between the various instruments.
MIDI channel	For each part, one MIDI channel number from # 0 to # 15 can be assigned.
System No.	Separate from MIDI channels, each FB-01 can be assigned system numbers from 1 to 16. Thus, each FB-01 can be controlled independently, even though several FB-01 units are used in the total system.
Note range	Acceptable Note Range C2 ~ G8 Nominal Note Range 8 octaves.

Voice

Number of preset voices : 240
 Number of voices which can be defined by the user: 96
 (Backed up by battery)
 Basic voice data is interchangeable with SFG01 and SFG05.
 The notes can be assigned to any instrument (part).
 A controller and special software (with MIDI capability) are necessary to produce voices.

Configuration Data Listing

Listed in the table below is the data of configuration No. 17 which is one of the preset.
 The FB-01 has a total of 20 types of configuration data, namely, 4 types which are preset (in ROM) and 16 types (with battery backup) for the user (in RAM).

CONFIGURATION NUMBER	17	NAME	single							
VOICE FUNCTION COMBINE	ON	KEY-CODE NUMBER RECEIVE MODE	ALL							
INSTRUMENT NUMBER			1	2	3	4	5	6	7	8
INST ASSIGN	MIDI CHANNEL		1	2	3	4	5	6	7	8
	NUMBER OF NOTES		8	0	0	0	0	0	0	0
	KEY-CODE NUMBER LIMIT/L		C-2	C-2	C-2	C-2	C-2	C-2	C-2	C-2
	KEY-CODE NUMBER LIMIT/H		G8	G8	G8	G8	G8	G8	G8	G8
VOICE SELECT	VOICE NUMBER		1	1	1	1	1	1	1	1
	VOICE BANK NUMBER		3	3	3	3	3	3	3	3
INST FUNCTION	OUTPUT LEVEL		127	127	127	127	127	127	127	127
	OCTAVE TRANSPOSE		0	0	0	0	0	0	0	0
	DETUNE		0	0	0	0	0	0	0	0
	STEREO		L+R	L+R	L+R	L+R	L+R	L+R	L+R	L+R
	LFO ENABLE		ON	ON	ON	ON	ON	ON	ON	ON
VOICE FUNCTION	PITCHBENDER RANGE		2	2	2	2	2	2	2	2
	PORTAMENTO TIME		0	0	0	0	0	0	0	0
	POLY/MONO		POLY	POLY	POLY	POLY	POLY	POLY	POLY	POLY
	INPUT CONTROLLER (PMD)		WHEEL	WHEEL	WHEEL	WHEEL	WHEEL	WHEEL	WHEEL	WHEEL

Effects

[Effects settings are possible for each instrument (part).]

Sound volume	128 steps
PAN	L, LR, R
Detune	± 100 cent Max.
Transpose	± 2 octaves Max.

Special Effects

Portamento time	128 steps
Pitch bender range	1 octave Max.
Poly/mono mode switching possible.	
AMD control	After touch, modulation wheel, breath control or foot control can be selected.
PMD control	After touch, modulation wheel, breath control or foot control can be selected.

*These special effects can be set either for each voice or for each part.

Configurations

Configurations included 4 types
 Configurations so that the USER can define 16 types
 (backed up by battery)
 "Configuration" is a general term for a series of parameters such as various modes and numerical values which the FB-01 utilizes to generate tones.

Combine Function

When the combine mode is ON, all voice function data such as bender amount and portamento time are recalled when a voice is loaded. When the combine mode is OFF, the voice function data is NOT recalled with the loaded voice.

■ CIRCUIT OPERATION

1. CPU Clock Circuit

A 12MHz crystal is utilized in the clock generation circuit to provide the clock signal for the CPU and sound source. A 6MHz clock signal is applied to the clock terminal (pin 6) of the CPU via IC14, a divide by 2 circuit.

2. Sub-clock Circuit

A 4MHz crystal is utilized in the clock generation circuit to provide the clock signal for the OPP, DAC, and MIDI circuitry. It is divided down to 500KHz by IC9 (74HC161) and applied to the USART (μ PD71051) and OPP (YM2164).

3. Reset Circuit

POWER ON RESET is generated by means of the reset circuit consisting of C87, R37, R72 and ZD1. The circuit is also connected to the Chip Enable (CE) signal generation circuit for the RAM battery backup function so that the RAM data is protected at power OFF.

4. CPU, ROM, and RAM

The CPU operates on the basis that the system clock is about 6MHz. For this reason, the access time of the bus connecting elements such as ROM and RAM must be faster than 150nS.

The ROM, from 0000H to 7FFFH, is for the voice data and program area as well as for configuration data area.

The RAM, from 8000H to BFFFH, is used as the area for storing various types of register and stack information.

The RAM memory is also utilized for storing the Configuration Data, and the User Memory Data. This RAM area is battery backed-up in order to save or hold the saved data.

5. The Sound Source Circuit

This circuit consists of a 4-operator, 8-voices FM sound source (OPP YM2164) and the YM3012 DAC. The FM sound source circuit operates according to the data from the CPU. There are two channels for the audio output and they can produce different voices.

6. Switch Scan Circuit

This circuit scans the ON/OFF states of the 8 switches by means of IC18 (74HC244) which is directly connected to the CPU data bus.

7. MIDI Circuit

The USART (μ PD71051: 8251 compatible) is used as the Transmitting and Receiving device of the MIDI circuit. It conforms to the MIDI standard V1.0.

■ SYSTEM BLOCK DIAGRAM

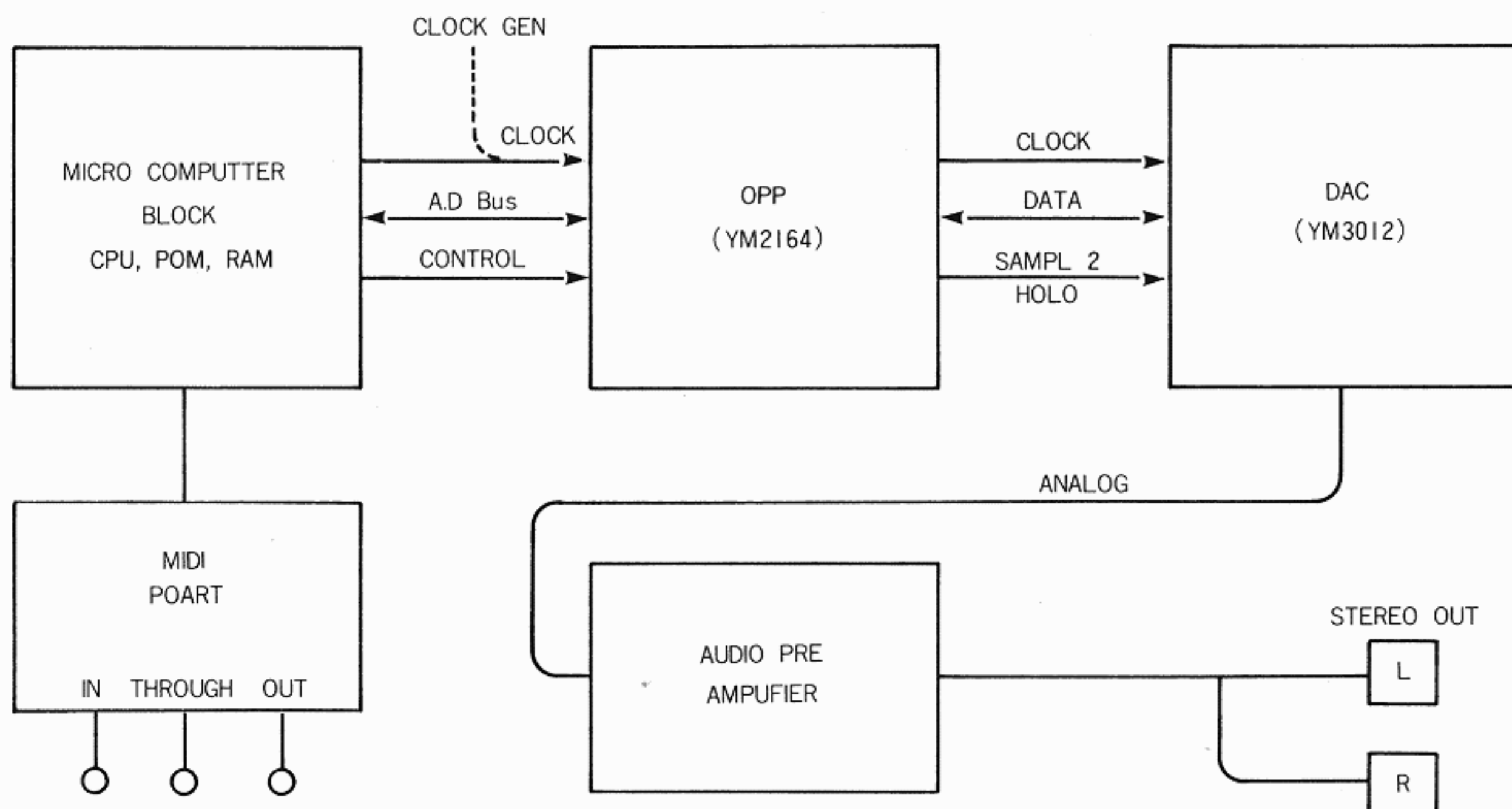

■ FB-01 MEMORY MAP & I/O PORT MAP

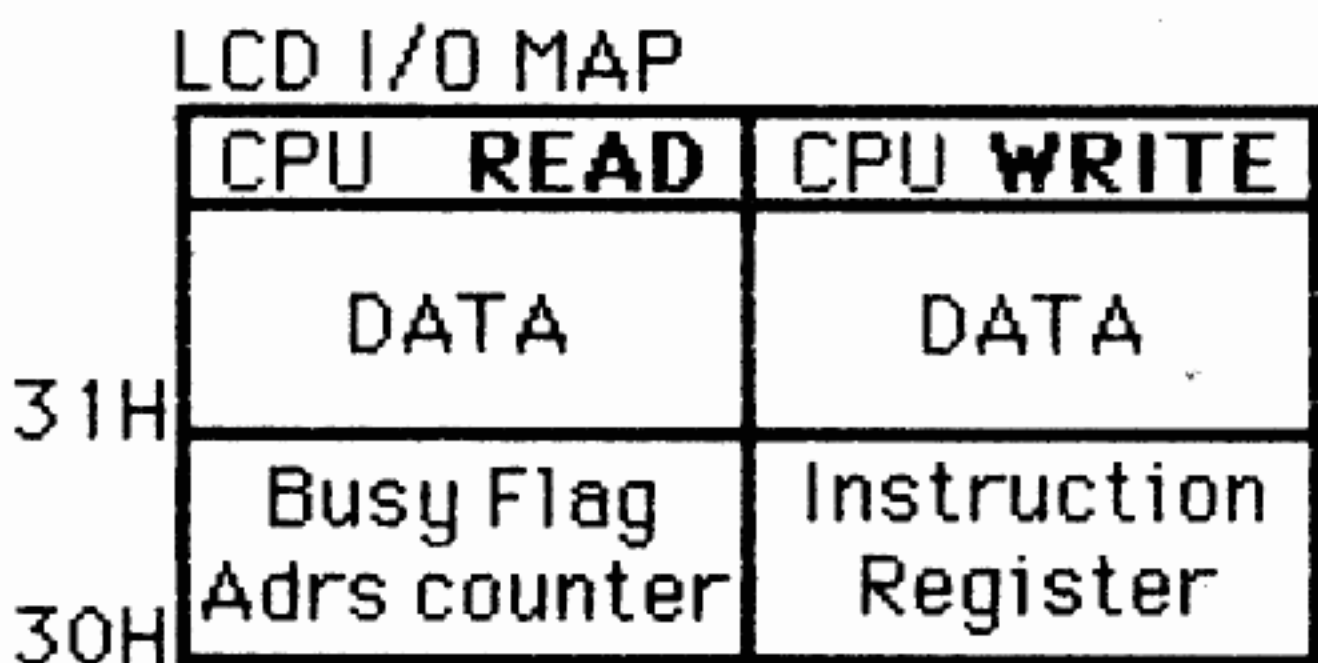
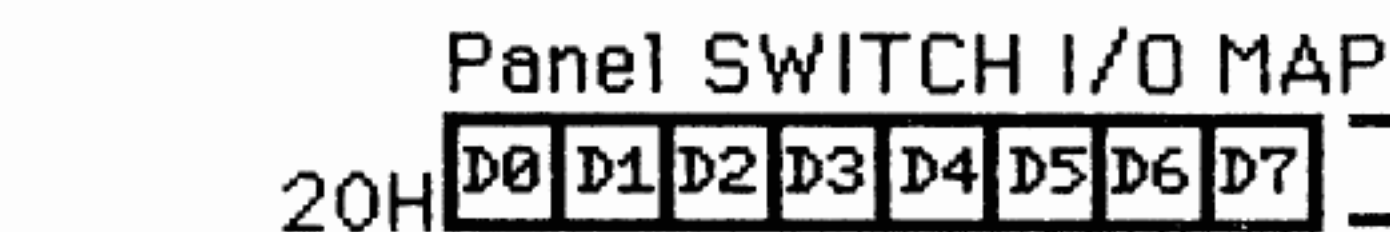
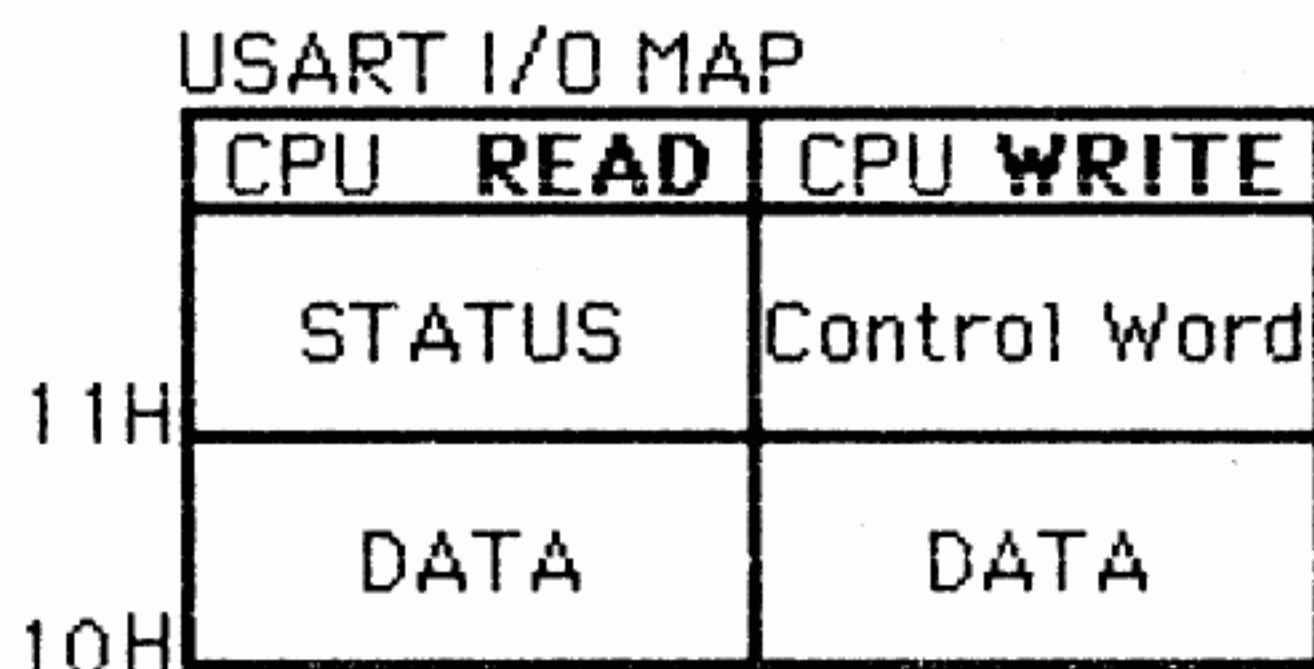
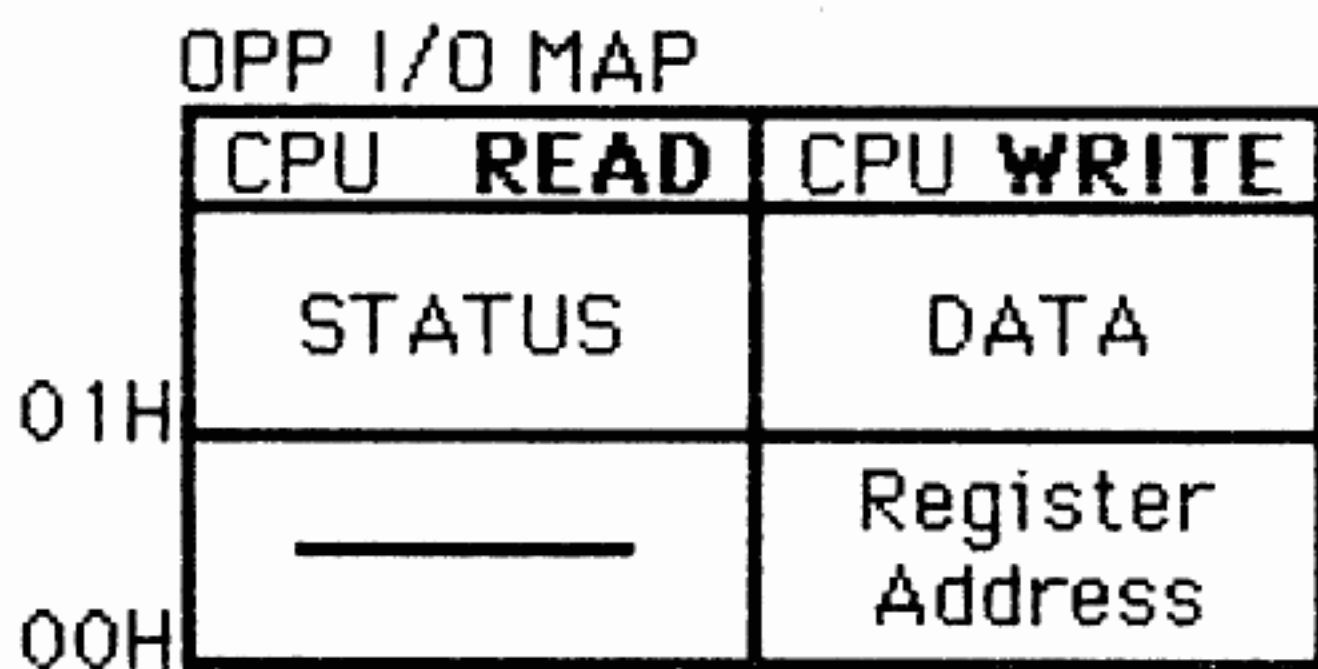
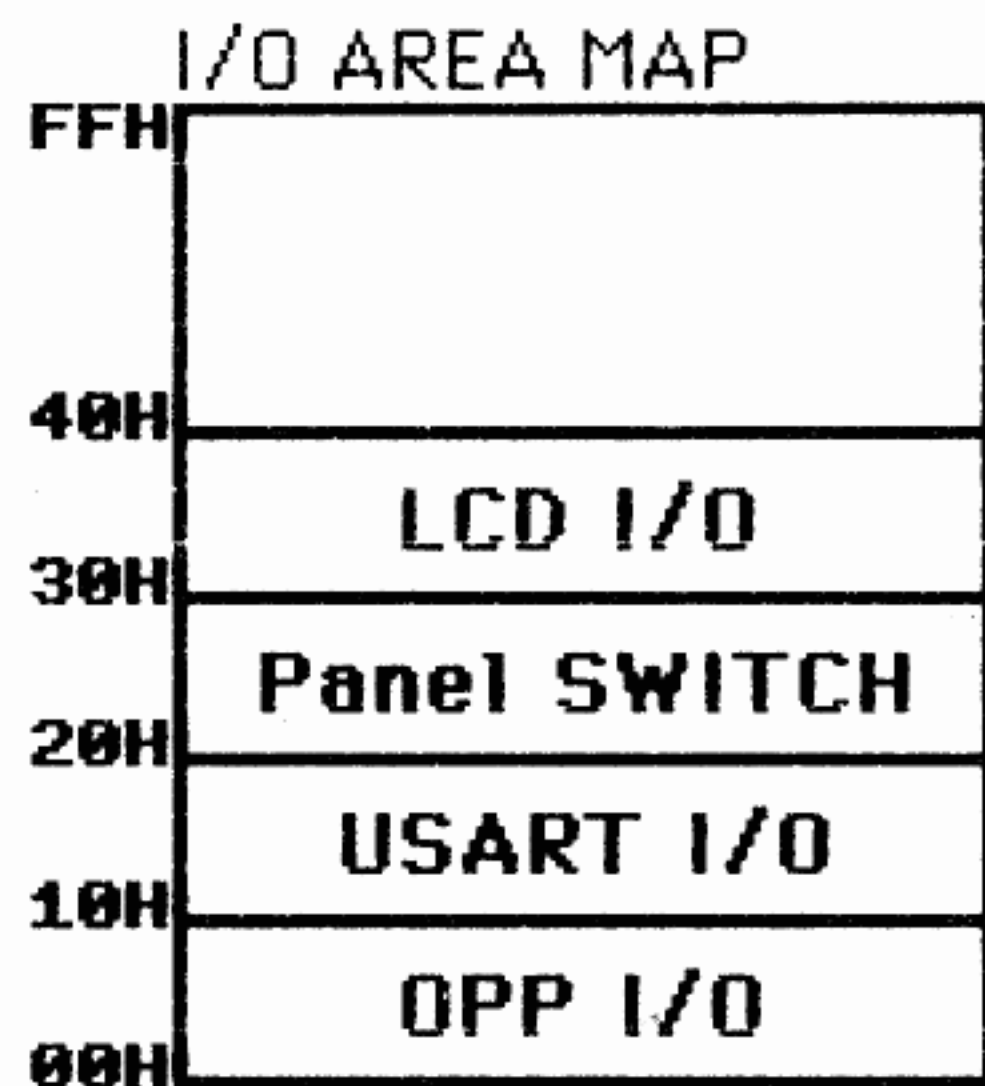
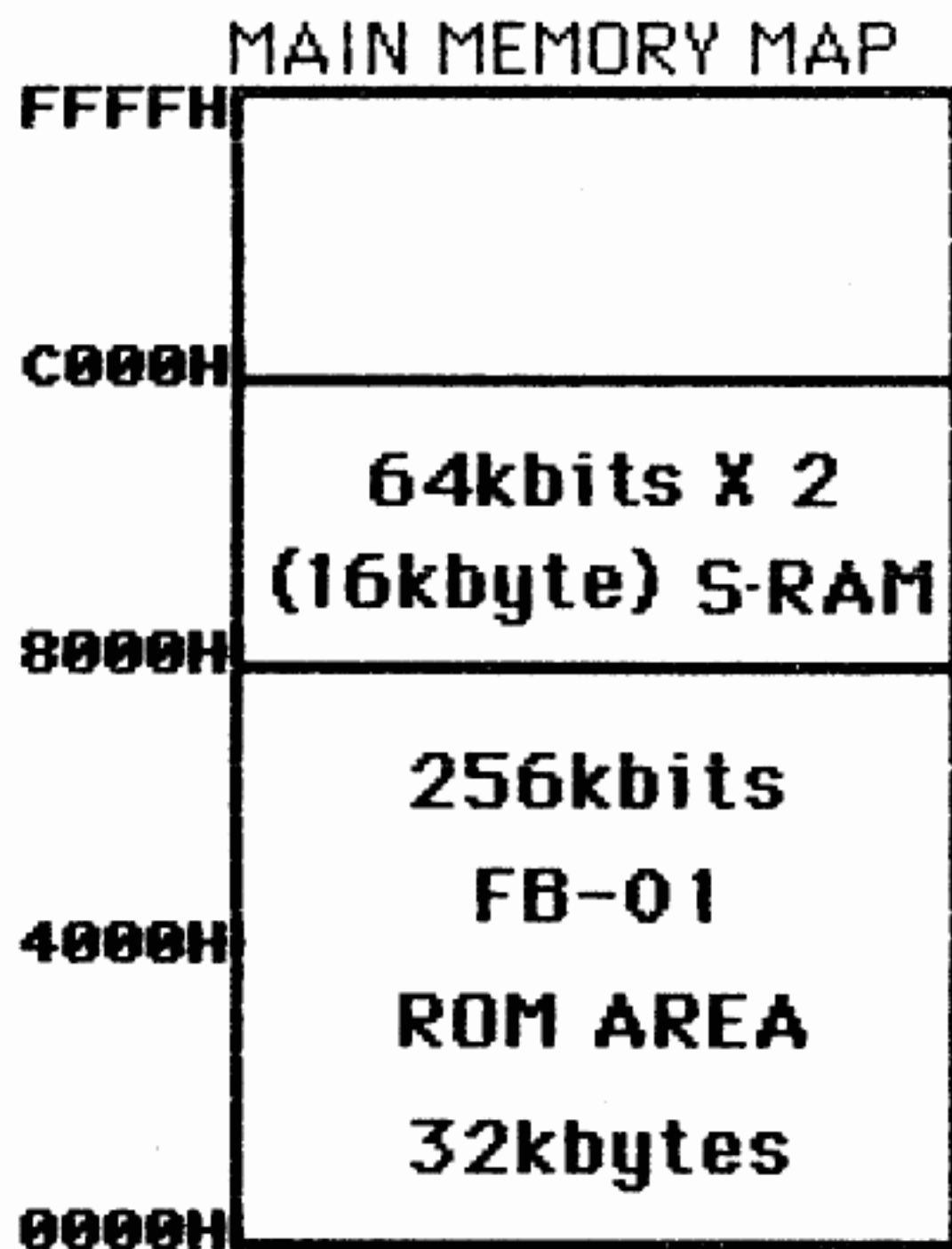

BIT	Switch Name
D7	+1/Yes
D6	-1/ No
D5	Voice Select
D4	Voice Function
D3	Inst Function
D2	Inst Assign
D1	Inst Select
D0	System set up

OPERATIONAL CHECK BY UTILIZING THE TEST PROGRAM

Test Mode Entry

Before executing the Test Mode or a repair save the user information, all data stored in the S-RAM will be erased when the Test Mode is activated.

Depress and hold the "SYSTEM SET UP", "INST SELECT" and "DATA ENTRY - 1/NO". Switches on the front panel while turn ON the POWER switch, and the test program, starts operating. Test data is written in the S-RAM memory area which is from 8000 to BFFFH (indicated as FFFFH). When this process is complete "S-RAM WRITE END" is displayed, which means that the data for the backup circuit check has been written in the S-RAM.

TEST MENU MODE

Pressing the "VOICE SELECT" switch after the "S-RAM WRITE END" message is displayed sets the TEST menu mode. The "VOICE SELECT" switch is also used when setting the mode back to the TEST menu mode from other TEST mode routines. Once the mode is set to the TEST menu, the message " = = IFB TEST = =" will be displayed on LCD.

Battery-backup function & S-RAM check

1. Turn ON the battery backup switch.
2. Press the proper switch to set to TEST MODE.
3. If the S-RAM doesn't have the test data written in, writing of the prescribed data starts automatically.
4. Upon completion of writing the message "S-RAM WRITE END" is displayed. (Press the "VOICE SELECT" key to return to the menu.)
5. Turn OFF the power and wait for two hours.
6. Turn ON the power again, set to the TEST mode and check that "S-RAM CHECK OK!" message is displayed. When turning ON the power, be sure to start in the TEST mode. If having started in the NORMAL mode, repeat this process from above step 2.

If the data in S-RAM has been erased, the prescribed data is automatically written in. However, if "S-RAM WRITE END" is not displayed after the comparative check, it means that the S-RAM related part is defective and the check after this will become ineffective.

LCD Check

1. Press the proper switches to enter the TEST mode.
2. Press the "VOICE-SEL" switch to select the TEST menu mode the following message should be displayed " = = IFS TEST = =".
3. Press the "SYSTEM" switch to select the LCD TEST mode.
4. Check to make sure that LCD displayed characters as shown in Table 1 which will increment from COH to FFH. During each increment 16 characters are displayed at a time.
5. To stop the sequence and display routine of 16 characters press the VOICE FUNC switch, and the display will stop temporarily.
6. To exit the LCD display routine, press the SYSTEM switch.
7. As a final step, check to make sure that the CHARACTER GENERATE RAM display appears as shown in the figure.
8. Also, check that the color, contrast, visual angle and visual angle range are appropriate.

CPP TIMER Test

1. Press the specified switch to increment to the TEST menu mode.
2. Press " - 1/NO" switch to advance to the TIMER TEST PROGRAM.
3. Check to make sure that the "TIMER OK!" message is displayed.

MIDI Function

1. Prepare two FB-01 standard units (Standard unit is a FB-01 unit that is known to be functioning correctly).
2. Connect them as shown in Fig.2 by using the MIDI cable included in the package.
3. Press the specified switch to increment to the TEST menu mode.
4. Press the INST SEL switches of the standard units ① and ② in Fig.2 to advance to the MIDI TEST mode. (UART MIDI CHECK)
5. Press the INST SEL switch of the unit being tested to advance to the MIDI TEST mode.
6. Check to make sure that after a few seconds, the "MIDI OK!" message is displayed on all three units.

AMP Characteristics

1. Terminate both L and R terminals with 47K Ω resistors.
2. Press the specified switch to advance to the TEST menu mode.
3. Press the + 1/Yes switch to run the OPP SOUND CHECK PROGRAM.
4. Press the - 1/No switch to initiate the output of a 1kHz TEST signal.
5. Connect a frequency counter to either L or R terminal and check that frequency is within 1000Hz \pm 1Hz.
6. Using an AC voltmeter (level meter Model M-174A of NF make or equivalent), check to make sure that the FLAT characteristic is within \pm 0.3dB of the specified value and that the level difference between L and R is within 0.6dB.
7. Using an oscilloscope, check to make sure that the waveform is not distorted or clipped from.
8. Using a distortion meter, check to make sure that the distortion factor is within 0.5%.
9. Press SYSTEM, INST SEL, - 1/NO, + 1/YES, INST ASSIGN and INST FUNC switches one by one continuously and check that the reading of the AC voltmeter is within \pm 0.3% of the specified value.
10. Turn the power ON and OFF, and check that the AC voltmeter reading is less than 10mV then.
11. Check to make sure that the residual noise is less than 0.5mV in the TEST menu mode.
12. With the same settings as specified in step No.6, add a 1k Ω to the load resistor and check that the output level changes to one half the original level.

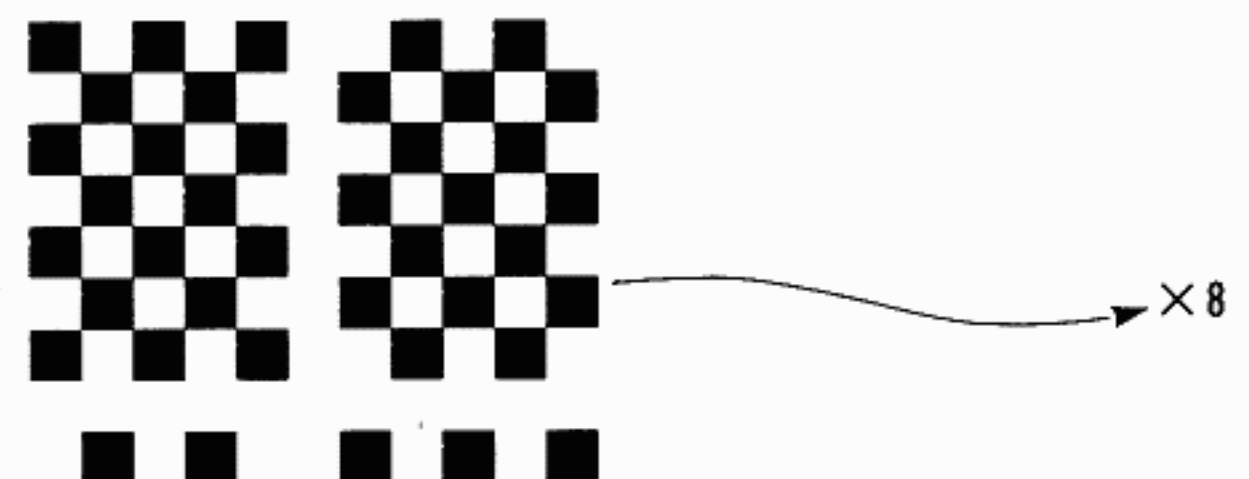

(Fig. 1)

LCD Pattern Display

Character Pattern Table (Table 1)

High order Low order 4 bit 4 bit	0000	0010	0011	0100	0101	0110	0111	1010	1011	1100	1101	1110	1111
XXXX0000	CG RAM (1)		0	1	2	3	4	5	6	7	8	9	0
XXXX0001	(2)	!	@	#	\$	%	&	'	()	*	+	,
XXXX0010	(3)	"	#	\$	%	&	'	()	*	+	,	.
XXXX0011	(4)	*	3	4	5	6	7	8	9	:	;	<	=
XXXX0100	(5)	+	4	5	6	7	8	9	:	;	<	=	>
XXXX0101	(6)	+	5	6	7	8	9	:	;	<	=	>	0
XXXX0110	(7)	6	7	8	9	:	;	<	=	>	0	1	2
XXXX0111	(8)	7	8	9	:	;	<	=	>	0	1	2	3
XXXX1000	(1)	8	9	:	;	<	=	>	0	1	2	3	4
XXXX1001	(2)	9	:	;	<	=	>	0	1	2	3	4	5
XXXX1010	(3)	:	;	<	=	>	0	1	2	3	4	5	6
XXXX1011	(4)	;	<	=	>	0	1	2	3	4	5	6	7
XXXX1100	(5)	<	=	>	0	1	2	3	4	5	6	7	8
XXXX1101	(6)	=	>	0	1	2	3	4	5	6	7	8	9
XXXX1110	(7)	>	0	1	2	3	4	5	6	7	8	9	0
XXXX1111	(8)	0	1	2	3	4	5	6	7	8	9	0	1

Connection for MIDI Function Test

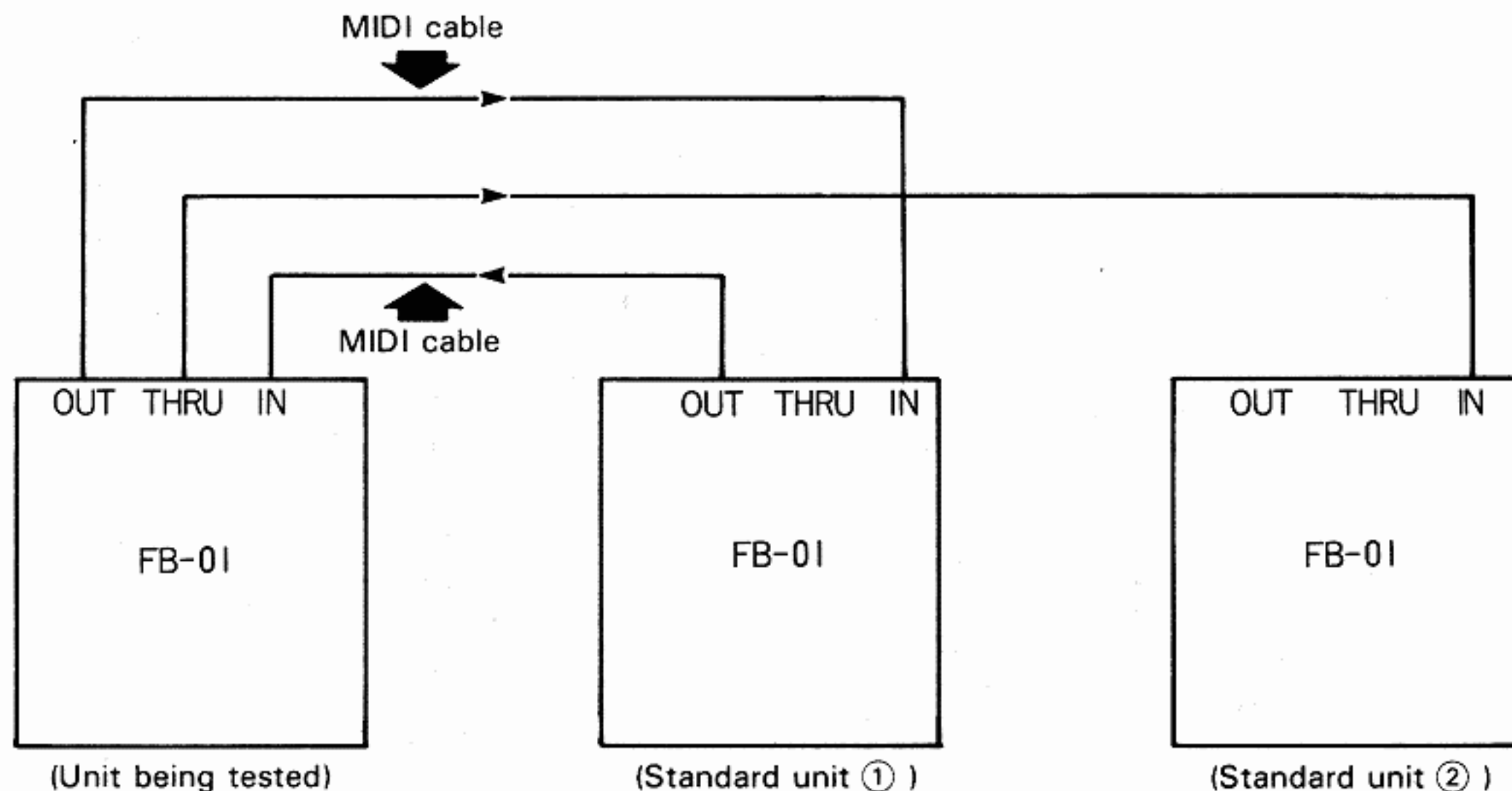

Connection diagram for MIDI Function Test (Fig.2)

A "Standard unit" is defined as a properly functioning FB-01.

Three FB-01 units are required if the system channel test is to be performed.

FM Power Source (OPP: YM2164) and D/A (YM3012) Block Diagram

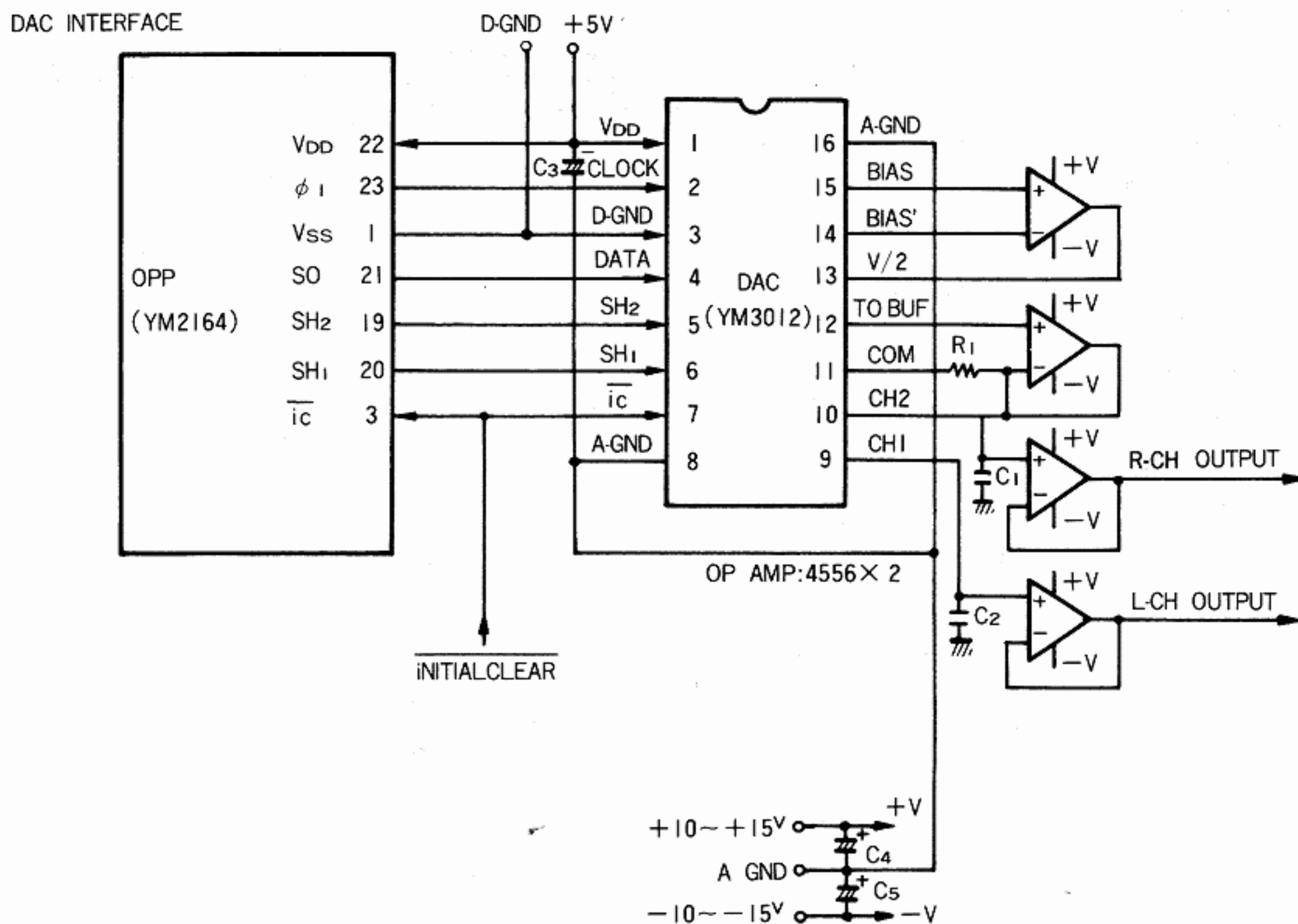

Boot procedure

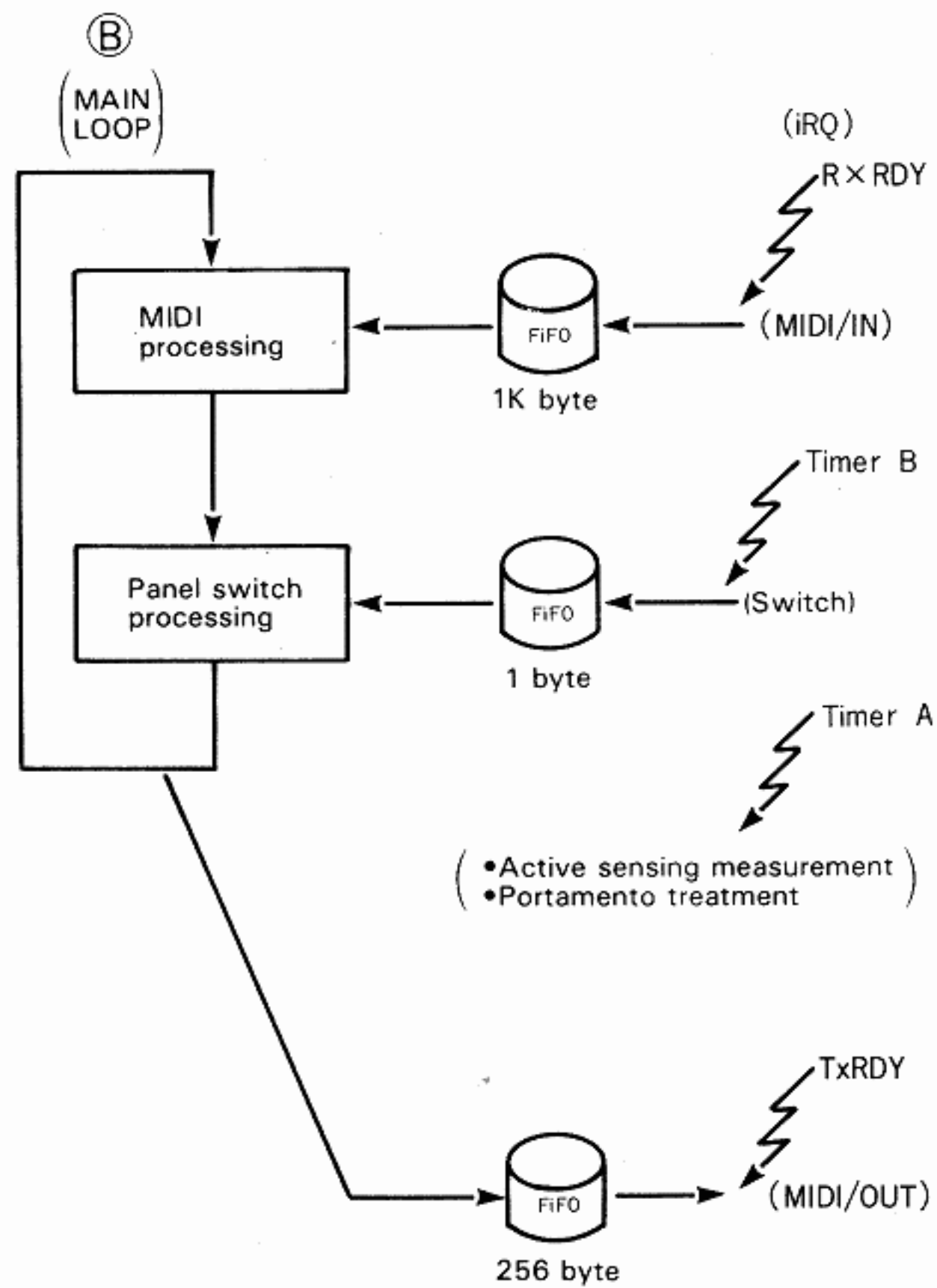
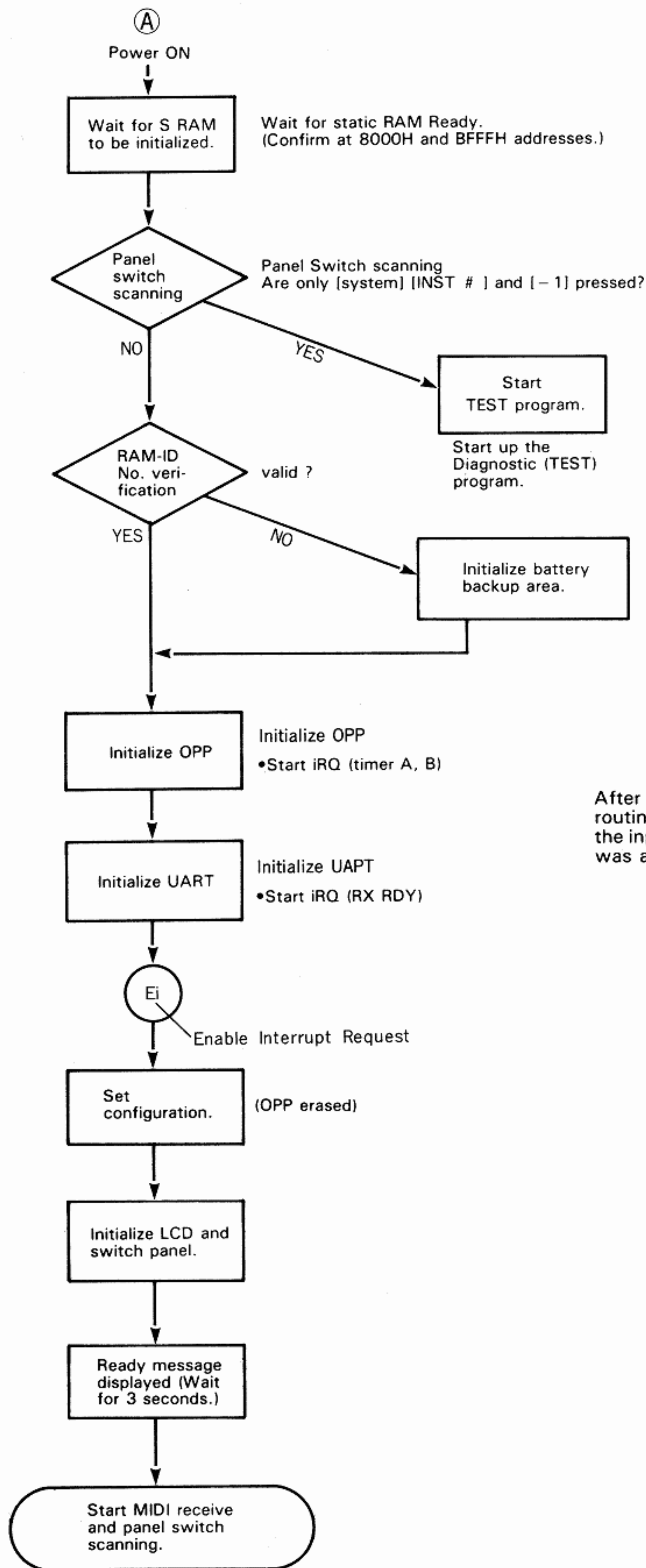

After the power is turned ON, the FB-01 is initialized by the (A) routine, and then the MAIN LOOP which is the (B) routine waits for the input and executes each command according to the function that was activated.

DESCRIPTION ON MIDI

The MIDI signals which the FB-01 can use are classified as follows.

Channel Message

- Channel voice message
This is a signal to transmit and receive the information which is directly related to playing. However, for the FB-01, this type of message can only be received, but it can not be transmitted.

The main messages are as follows.

Key note number
Key ON/OFF signal
Key velocity
Change of voice number
Pitch bender
Various control information

- Channel mode message
This message is a signal to indicate the mode which will dictate the processing of the transmitted MIDI data. One example of this type of message is a polyphonic/monophonic switching message.

System Message

- System common message
This message executes the total system setup and performs such jobs as locating the beginning of the sequence data. However, this function is not used for the FB-01.
- System real time message
This message synchronizes sequencer and rhythm units when the automatic play function is used. These messages include commands such as "play start", "play stop" and "synchronous clock".
- System exclusive message
With the FB-01, the system exclusive messages are classified into three groups as described below.

① Instrument message

This message specifies what is to be controlled with the system number and instrument number. It controls the instrument by changing (parameter change) the voice data, instrument function data, voice function data, etc.. It also dumps the voice data set for each instrument.

② System message

This message specifies what is to be controlled with the system number (system channel number). It changes the parameter common to the system (parameter change) and dumps the voice data for 48 voices and the configuration data.

③ Channel message

This message specifies what is to be controlled with the MIDI channel number. The FB-01 operates only when the receiving channel coincides. The information that it controls is the same as the parameter change data of the instrument message, however, the data to be controlled can be specified with the channel number and not with the instrument number.

System Channel Number

The system channel number is the channel number which is necessary to transmit and receive the system message or instrument message included in the system exclusive data. The number can be set within the range from 1 to 16 by using the SYSTEM SETUP, +1 and -1 switches. The system channel number is entirely different from the MIDI channel number.

When a number of FB-01 units are used in a system setup and, if a different system channel number is assigned for each FB-01, it is possible to control a particular FB-01.

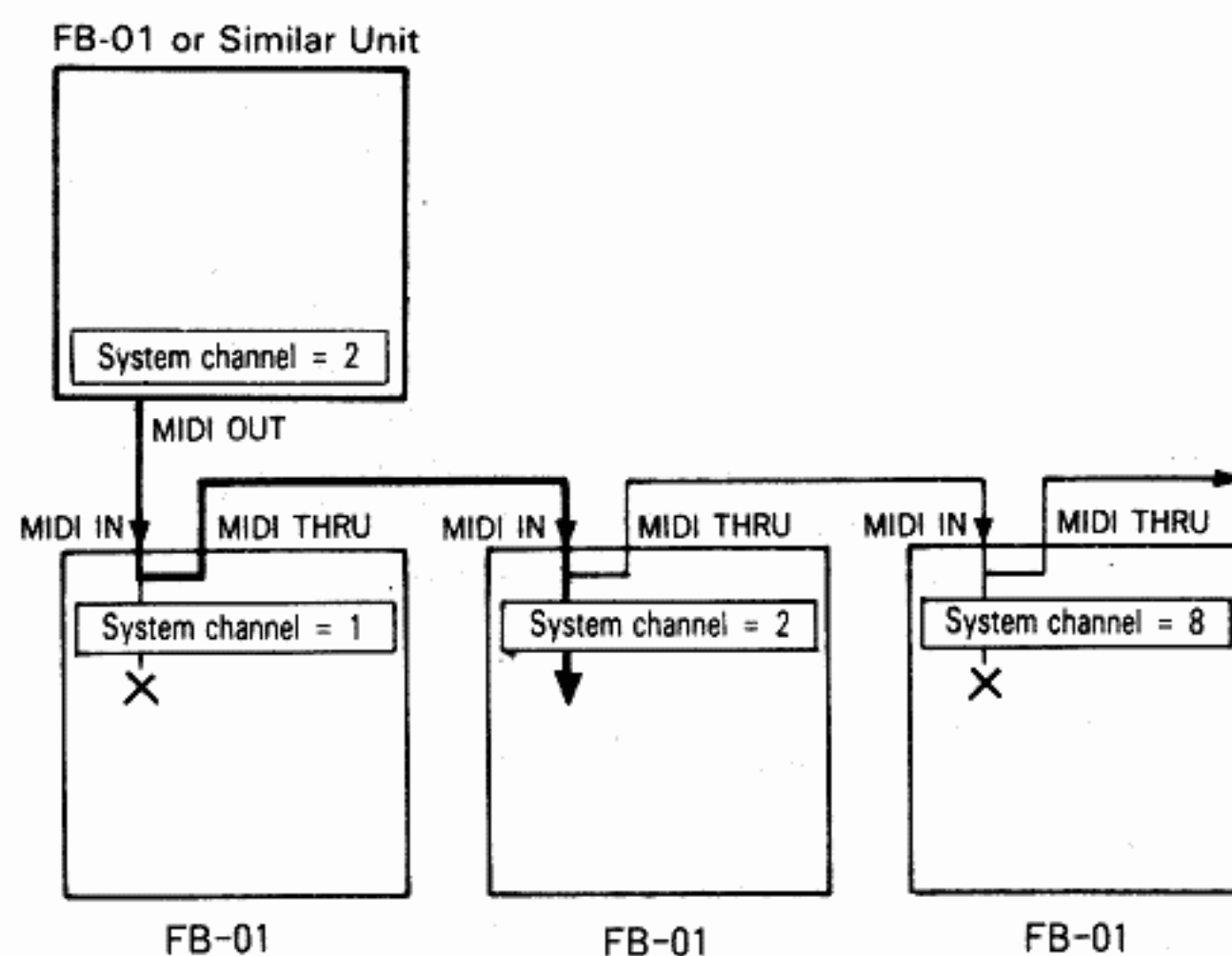

■ MIDI RECEIVE DATA FORMAT 1 (CHANNEL MESSAGE, SYSTEM MESSAGE)

Channel voice message

① Key OFF

Status 1000nnnn (8nH:n=Channel No.)
Note No. 0kkkkkkk (k=0:C-2~127:G8)
Velocity 0vvvvvvv (v: ignored)
n=0~15 (0H~FH)

② Key ON/OFF

Status 1001nnnn (9nH:n=Channel No.)
Note No. 0kkkkkkk (k=0:C-2~127:G8)
Velocity 0vvvvvvv (v=1~127:Key ON)
(v=0:Key OFF)

* The output level of each operator varies according to the velocity at the time of reception. How much it varies depends on the velocity sensitivity set by the parameters (data) of each voice. Also, with a voice whose attack rate velocity sensitivity is set, the attack rate varies as well.

* The note range of this unit is from D# -1 to D7, it produces D7 at the highest and D# -1 at the lowest even when a higher note information or lower note information than the range is received. For example, when D# -7 to D8 information is transmitted, D# -6 to D7 tones are produced.

③ Control change

Status 1011nnnn (BnH:n=Channel No.)
Control No. 0ccccccc
Control value 0vvvvvvv

Control No.	Control value
c=1 Modulation wheel	v=0~127
c=2 Breath controller	v=0~127
c=4 Foot controller	v=0~127
c=5 Portamento time	v=0~127
c=7 Volume	v=0~127
c=10 Pan	v=0: L v=64: L+R v=127: R
c=64 Sustain switch	v=0:OFF, 127:ON
c=65 Portamento switch	v=0:OFF, 127:ON
c=66 Sostenuto switch	v=0:OFF, 127:ON

* The control No. 1 receives a signal when the "WHEEL" controller is specified for the pitch modulation controller. Likewise, No.2 and No.4 receive a signal when "BREATH" and "FOOT" controllers are specified, respectively.

④ Program change

Status 1100nnnn (CnH:n=Channel No.)
Program No. 0ppppppp (p=0:47)

⑤ After touch

Status 1101nnnn (DnH:n=Channel No.)
Control value 0vvvvvvv

* Signal is received when the "TOUCH" control is specified for the pitch modulation controller.

⑥ Pitch bend

Status 1110nnnn (EnH:n=Channel No.)
Value (LSB) 0uuuuuuu
Value (MSB) 0vvvvvvv

Channel mode message

① All note OFF

② MONO mode ON

③ POLY mode ON

Status 1011nnnn (BnH:n=Channel No.)
Control No. 0ccccccc
Control value 0vvvvvvv

c=123 v=0 All note OFF
c=126 v=1 MONO MODE ON

* Operates only in POLY mode
c=127 v=0 POLY MODE ON
* Operates only in MONO mode

* When the MONO ON/POLY ON mode is switched, the sound being generated is stopped and sostenuto is turned OFF.

System real time message

① Active sensing (FEH)

* Once this code is received, sensing is started. If no status or data is received within 300msec, the MIDI receive buffer is cleared and the sound being generated is stopped.

② Real time clock (F8H)

* This clock for system timing and is sent at a rate of 24 clicks per quarter note.

③ Start (FAH)

④ Continue (FBH)

⑤ Stop (FCH)

* Counting is started by the start or continue signal and stopped by the stop signal.

■ MIDI RECEIVE DATA FORMAT 2 (SYSTEM EXCLUSIVE MESSAGE)

Instrument message

- ① Parameter change (1 byte)
- | | |
|---------------|----------------------------------|
| Status | 11110000(F0H) |
| ID No. | 01000011(43H) |
| Sub-status | 01110101(75H) |
| System No. | 0000s s s s (s = system No.) |
| Message No. | 00011 i i i (i = instrument No.) |
| Parameter No. | 0ppppppp (p = 0 ~ 3FH) |
| Data | 0ddddddd |
| EOX | 11110111(F7H) |

This message changes the parameter related to the configuration data and LFO.

* Refer to Parameter list 1.

- ② Parameter change (2 byte)
- | | |
|---------------|---|
| Status | 11110000(F0H) |
| ID No. | 01000011(43H) |
| Sub-status | 01110101(75H) |
| System No. | 0000s s s s (s = system No.) |
| Message No. | 00011 i i i (i = instrument No.) |
| Parameter No. | 0ppppppp (p = 40H ~ 7FHH) |
| Data | 0000dddd(Data Low)
0000dddd(Data High) |
| EOX | 11110111(F7H) |

This message changes the parameter related to each voice. The data is sent in the order of a Low 4 bit code and a High 4 bit code of the source data.

* Refer to Parameter list 6 (voice parameter list) for the parameter No.

- ③ Voice bulk data dump
- | | |
|---------------|----------------------------------|
| Status | 11110000(F0H) |
| ID No. | 01000011(43H) |
| Sub-status | 01110101(75H) |
| System No. | 0000s s s s (s = system No.) |
| Message No. | 00101 i i i (i = instrument No.) |
| Operation No. | 01000000(40H)
00000000(00H) |
| EOX | 11110111(F7H) |

This message dumps the data for one voice which is set in the voice buffer of the instrument specified by the system channel and instrument number.

- ④ Store into voice RAM (voice RAM 1 ~ 96) of current voice data
- | | |
|---------------|----------------------------------|
| Status | 11110000(F0H) |
| ID No. | 01000011(43H) |
| Sub-status | 01110101(75H) |
| System No. | 0000s s s s (s = system No.) |
| Message No. | 00101 i i i (i = instrument No.) |
| Operation No. | 00000000(00H) |
| Data | 00dddddd(d = voice No.) |
| EOX | 11110111(F7H) |

This message stores the currently selected instrument voice data in the voice RAM (voice RAM No. 1 ~ 96).

System message

- ① System parameter change
- | | |
|---------------|------------------------------|
| Status | 11110000 (F0H) |
| ID No. | 01000011 (43H) |
| Sub-status | 01110101 (75H) |
| System No. | 0000s s s s (s = system No.) |
| Message No. | 00010000 (10H) |
| Parameter No. | 0ppppppp |
| Data | 0ddddddd |
| EOX | 11110111 (F7H) |

This message changes the parameter common to the system. It can also change the configuration No.

* Refer to Parameter list 2 for the parameter No.

- ② Voice RAM 1 (for 48 voices) bulk data dump
- | | |
|------------|-------------------------------|
| Status | 11110000 (F0H) |
| ID No. | 01000011 (43H) |
| Sub-status | 0010s s s s (s = channel No.) |
| Format No. | 00001100 (0CH) |
| EOX | 11110111 (F7H) |

This message dumps the voice RAM 1 contents (voice data).

- ③ Each voice bank (for 48 voices) bulk data dump
- | | |
|---------------|-------------------------------|
| Status | 11110000 (F0H) |
| ID No. | 01000011 (43H) |
| Sub-status | 01110101 (75H) |
| System No. | 0000s s s s (s = channel No.) |
| Message No. | 00100000 (20H) |
| Operation No. | 00000000 (00H) |
| Bank No. | 00000xxx (x = 1 ~ 7) |
| EOX | 11110111 (F7H) |

This message dumps the voice data for 48 voices in the voice bank specified by the bank No.

- ④ Current configuration data dump
- | | |
|---------------|----------------------------------|
| Status | 11110000 (F0H) |
| ID No. | 01000011 (43H) |
| Sub-status | 01110101 (75H) |
| System No. | 0000s s s s (s = channel No.) |
| Message No. | 00100000 (20H)
00000000 (00H) |
| Operation No. | 00000001 (01H) |
| EOX | 11110111 (F7H) |

This message dumps the configuration data which is currently selected.

} Instrument voice data

⑤ Configuration data dump
 Status 11110000 (F0H)
 ID No. 01000011 (43H)
 Sub-status 01110101 (75H)
 System No. 0000ssss (s = channel No.)
 Message No. 00100000 (20H)
 Operation No. 00000010 (02H)
 000xxxxx (x = configuration No.)
 EOX 11110111 (F7H)

This message dumps the configuration data specified by the configuration No.

⑥ 16 configuration data dump
 Status 11110000 (F0H)
 ID No. 01000011 (43H)
 Sub-status 01110101 (75H)
 System No. 0000ssss (s = channel No.)
 Message No. 00100000 (20H)
 Operation No. 00000011 (03H)
 00000000 (00H)
 EOX 11110111 (F7H)

This message dumps all configuration RAM data. (This configuration data is programmed by the user and stored in the configuration RAM area).

⑦ Unit ID number dump
 Status 11110000 (F0H)
 ID No. 01000011 (43H)
 Sub-status 01110101 (75H)
 System No. 0000ssss (s = channel No.)
 Message No. 00100000 (20H)
 Operation No. 00000100 (04H)
 00000000 (00H)
 EOX 11110111 (F7H)

Table 1

Parameter No.	Parameter Name	Value
00~0F	Refer to Parameter list 5	
10	LFO Speed	0~127 (Max)
11	AMD	0~127
12	PMD	0~127
13	Wave Form	0~3
14	LFO Load enable	0, 1(on)
15	LFO Sync	0, 1(on)
16	AMS	0~3
17	PMS	0~7
18~3F	Reserved area	

< Parameter list 1 >

⑧ Configuration data store
 Status 11110000 (F0H)
 ID No. 01000011 (43H)
 Sub-status 01110101 (75H)
 System No. 0000ssss (s = system No.)
 Message No. 00100000 (20H)
 Operation No. 01000000 (40H)
 Data 000ddddd (d = configuration No.)
 EOX 11110111 (F7H)

This message restores the current configuration in the area whose number is specified (configuration RAM area).

Table 2

Parameter No.	Parameter Name	Data
00~07	Reserved area	
08	Voice function combine	0, 1(on)
09	LFO Speed	0~127
0A	AMD	0~127
0B	PMD	0~127
0C	LFO Wave Form	0~3
0D	KC# Receive Mode	0~2*1
0E~1F	Reserved area	
20	System channel number	0~15
21	Memory protect	0, 1(on)
22	Configuration number	0~19
23	Master tune	0~127*2
24	Master output level	0~127
25~7F	Reserved area	

*1 : 0 = ALL, 1 = EVEN, 2 = ODD

*2 : 2's Complement

< Parameter list 2 >

■ OTHER SYSTEM MESSAGES

Bulk data

This message transmits multiple data such as voice data and configuration data together, at one time. A byte count to indicate the data size is added at the beginning of the data and a check sum is sent at the end to verify the data transmission.

* There are two format types for this type of data.

One transmits the source data as it is and the other divides the source data into a Low 4 bit code and a High 4 bit code, it then transmits this data in the order of Low and High codes.

* The check sum is the low order 7 bits of the 2's complement of the added data byte value.

① 48 voice bulk data

Voice data for the 48 voices in the voice RAM 1.

```

Status      11110000 (F0H)
ID No.     01000011 (43H)
Sub-status 0000ssss (s = channel No.)
Format No. 00001100 (0CH)
Byte count 00100000 (20H)
           00000000 (00H)
Data       0000dddd (Data Low)
           0000dddd (Data High)
           |
           0000dddd (Data Low)
           0000dddd (Data High)
Check sum  0eeeeeee
Byte count 00010000 (10H)
           01000000 (40H)
Data       0000dddd (Data Low)
           0000dddd (Data High)
           |
           0000dddd (Data Low)
           0000dddd (Data High)
Check sum  0eeeeeee
EOX       11110111 (F7H)
    
```

Address	Parameter	Data
000 ~007	Name	ASCII
008 ~01F		00
020 ~C20	Voice data 64Bytes × 48Voices	

* Voice data includes 48 voices, each voice requires 64 bytes of data. Refer to Voice parameter list.

< Parameter list 3 >

② 48 voices bulk data

This bulk data for 48 voices is transmitted to the bank specified by the bank No.

```

Status      11110000 (F0H)
ID No.     01000011 (43H)
Sub-status 01110101 (75H)
System No. 0000ssss
Message No. 00000000 (00H)
Operation No. 00000000 (00H)
Bank No.   00000xxx
Byte count 00100000 (20H)
           00000000 (00H)
Data       0000dddd (Data Low)
           0000dddd (Data High)
           |
           0000dddd (Data Low)
           0000dddd (Data High)
Check sum  0eeeeeee
Byte count 00100000 (10H)
           00000000 (40H)
Data       0000dddd (Data Low)
           0000dddd (Data High)
           |
           0000dddd (Data Low)
           0000dddd (Data High)
EOX       11110111 (F7H)
    
```

③ Current configuration

This message is transferred to the configuration buffer.

```

Status      11110000 (F0H)
ID No.     01000011 (43H)
Sub-status 01110101 (75H)
System No. 0000ssss
Message No. 00000000 (00H)
Operation No. 00000001 (01H)
           00000000 (00H)
Byte count 00000001 (01H)
           00100000 (20H)
Data       0ddddddd
           |
           0ddddddd
Check sum  0eeeeeee
EOX       11110111 (F7H)
    
```

④ Configuration memory

This message is transferred directly to the configuration RAM specified by the memory No.

Status	11110000 (F0H)
ID No.	01000011 (43H)
Sub-status	01110101 (75H)
System No.	0000ssss
Message No.	00000000 (00H)
Operation No.	00000010 (02H)
Memory No.	000xxxxx
Byte count	00000001 (01H) 00100000 (20H)
Data	0ddddddd }
	0ddddddd
Check sum	0eeeeeee
EOX	11110111 (F7H)

⑤ 16 configuration memory

All data of the configuration RAM.

Status	11110000 (F0H)
ID No.	01000011 (43H)
Sub-status	01110101 (75H)
System No.	0000ssss
Message No.	00000000 (00H)
Operation No.	00000011 (03H)
Memory No.	00000000 (00H)
Byte count	00010100 (14H) 00000000 (00H)
Data	0ddddddd }
	0ddddddd
Check sum	0eeeeeee
EOX	11110111 (F7H)

⑥ 1 voice bulk data

The voice data for one voice is set in the voice buffer of the instrument specified by the instrument No.

Status	11110000(F0H)
ID No.	01000011(43H)
Sub-status	01110101(75H)
System No.	0000ssss
Message No.	00001 i i i (i= instrument No.)
Operation No.	00000000(00H) 00000000(00H)
Byte count	00000001(01H) 00000000(00H)
Data	0000dddd(Data Low) 0000dddd(Data High) }
	0000dddd (Data Low) 0000dddd (Data High)
Check sum	0eeeeeee
EOX	11110111 (F7H)

Channel message

① MIDI channel specification (1 byte)

Status	11110000 (F0H)
ID No.	01000011 (43H)
Sub-status	0001nnnn (n = channel No.)
Parameter group	00010101 (15H)
Parameter No.	0ppppppp (p = 0 ~ 3FH)
Data	0ddddddd
EOX	11110111 (F7H)

This message specifies MIDI channel and changes the parameter. It also executes change of configuration data and LFO related changes.

* Refer to Table 1 for the parameter No.

② MIDI channel specification

Status	11110000 (F0H)
ID No.	01000011 (43H)
Sub-status	0001nnnn (n = channel No.)
Parameter group	00010101 (15H)
Parameter No.	0ppppppp (p = 40H ~ 7FH)
Data	0ddddddd (Data Low) 0000dddd (Data High)
EOX	11110111 (F7H)

This message specifies MIDI channel and changes the voice data.

* Refer to voice parameter list.

Event list

The FB-01 is capable of specifying a halftone higher or lower for subtle tone changes which cannot be specified with ordinary key code data. This function can be used by means of the system exclusive message. When the unit receives system exclusive messages, F0, 43, 75, 70, it is setup to receive the following messages, so that the fraction data can be added to the key ON message. These messages are received continuously until the unit receives F7 (end of exclusive) or the normal status byte of MIDI except the real time message.

```
Status      11110000 (F0H)
ID No.      01000011 (43H)
Sub-status  01110101 (75H)
            01110000 (70H)
Event data  0eeeeeee
            |
            0eeeeeee
EOX        11110111 (F7H)
```

Each data event starts with the event status byte. The length of one data event 2 to 6 bytes, is specified for each type of event. The term 'event status byte' indicates the status section in the event data. From now on it is referred to as 'status byte' but note that it is different from the normal status byte of MIDI.

Event status	Meaning
0nH	Key OFF
1nH	Key ON/OFF
2nH	Key ON/OFF
3nH	Control change
4nH	Program change
5nH	After touch
6nH	Pitch bender
7nH	Parameter change

< Parameter list 4 >

Event data format

① Key OFF

```
Status      0000nnnn(0nH: n = channel No.)
Note No.    0kkkkkkk
Fraction    0 f f f f f f (f = 0 ~ 127: + 100 cent)
```

② Key ON/OFF

```
Status      0001nnnn(1nH: n = channel No.)
Note No.    0kkkkkkk(k = 0: C-2 ~ 127: G8)
Fraction    0 f f f f f f (f = 0 ~ 127: + 100 cent)
Velocity    0vvvvvvv(v = 1 ~ 127: Key ON)
            (v = 1: Key OFF)
```

③ Key ON/OFF

```
Status      0010nnnn(2nH: n = channel No.)
Note No.    0kkkkkkk(k = 0: C-2 ~ 127: G8)
Fraction    0 f f f f f f (f = 0 ~ 127: + 100 cent)
Velocity    0vvvvvvv(v = 1 ~ 127: Key ON)
            (v = 1: Key OFF)
Duration    0 d d d d d d (Number of clocks LSB)
(Number of 0 d d d d d d (Number of clocks MSB)
clocks)    (d = 0: Key ON only)
```

- * When other than 0 is specified in the duration section, the clock is counted by means of the MIDI F8 signal (MIDI clock) which is transmitted from the device on the transmitting side, sound is generated for the specified clock and Key OFF takes place automatically. Thus the device on the transmitting side needs not send the Key OFF message.
- * When the MIDI start (FA) or continue (FB) signal is received, the MIDI clock starts counting.
- * When the start or continue signal is received, the # mark at the left end of the display keeps flashing till the stop signal is received.

④ Parameter change (1 byte)

This message changes the configuration data and voice data of each instrument.

```
Status      0111nnnn (7nH: n = channel No.)
Parameter No. 00pppppp
Data        0 d d d d d d
```

⑤ Parameter change (2 byte)

This message changes the voice data of each instrument.

```
Status      0111nnnn (7nH: n = channel No.)
Parameter No. 00pppppp
Data        0000 d d d d (Data Low)
            0000 d d d d (Data High)
```

- * The data section divides the source data into a Low 4 bit code and a High 4 bit code (2 bytes) and transmits them in the order of Low and High codes.
- * The data from the control change to pitch bender uses the same format as the channel message except the status byte.

PARAMETER LIST

Configuration parameter list

Parameter No.	Parameter Name	Data
	CONFIGURATION NAME	ASCII
	VOICE FUNCTION COMBINE MODE	0, 1 (1=COMBINE ON)
	LFO SPEED	0~127
	AMPLITUDE MODULATION DEPTH	0~127
	PITCH MODULATION DEPTH	0~127
	LFO WAVE FORM	0~3
	KEY-CODE NUMBER RECEIVE MODE	0~2 *1
	RESERVED	0
00	NUMBER OF NOTES	0~8
01	MIDI CHANNEL NUMBER	0~15
02	KEY-CODE NUMBER LIMIT/HIGH	0~127
03	KEY-CODE NUMBER LIMIT/LOW	0~127
04	VOICE BANK NUMBER	0~6
05	VOICE NUMBER	0~47
06	DETUNE	0~127 (2's complement)
07	OCTAVE TRANSPOSE	0~4 (2=CENTER)
08	OUTPUT LEVEL	0~127
09	PAN	0~127 (0=L, 64=L+R, 127=R)
0A	LFO ENABLE	0, 1 (1=ON)
0B	PORTAMENTO TIME	0~127
0C	PITCHBENDER RANGE	0~12
0D	MONO/POLY	0, 1 (1=MONO MODE)
0E	INPUT CONTROLLER (PMD)	0~4 *2
0F	RESERVED	
	Same as INST 1	INST 2
	do. INST 1	INST 3
	do. INST 1	INST 4
	do. INST 1	INST 5
	do. INST 1	INST 6
	do. INST 1	INST 7
	do. INST 1	INST 8

* 1 : 0=ALL, 1=EVEN, 2=ODD

* 2 : 0=OFF, 1=TOUCH, 2=WHEEL, 3=BREATH, 4=FOOT

Voice parameter list

Parameter No.	Parameter Name			Data
40~46			VOICE NAME	ASCII
47	[*****]		USER'S CODE	0~255
48	[*****]		LFO SPEED	0~255
49	[a*****]	[a]	ENABLE TO LOAD LFO DATA	0, 1 (1=ENABLE)
		[*]	AMPLITUDE MODULATION DEPTH	0~127
4A	[a*****]	[a]	LFO SYNC	0, 1 (1=SYNC ON)
		[*]	PITCH MODULATION DEPTH	0~127
4B	[0****000]	[*]	ENABLE OPERATOR	0, 1 (1=ON) BIT MAP OP4 ⇔ OP1
4C	[LRccccdd]	[L]	LEFT OUTPUT ENABLE	0, 1 (1=ON) FB-01 Ignored
		[R]	RIGHT OUTPUT ENABLE	0, 1 (1=ON) FB-01 Ignored
		[c]	FEED BACK LEVEL	0~6
		[d]	ALGORITHM	0~7
4D	[0aaa00bb]	[a]	PITCH MODULATION SENSITIVITY	0~7
		[b]	AMPLITUDE MODULATION SENSITIVITY	0~3
4E	[0**00000]	[*]	LFO WAVE FORM	0~3
4F	[*****]		TRANSPOSE	0~255 (2's complement)
50	[0*****]		TOTAL LEVEL	0~127 (0=Max. level)
51	[a***0000]	[a]	KEYBOARD SCALING (LEVEL) TYPE BIT0	0, 1
		[*]	VELOCITY SENSITIVITY FOR TL	0~7
52	[aaaabbbb]	[a]	KEYBOARD SCALING (LEVEL) DEPTH	0~15
		[b]	ADJUST FOR TL	0~15
53	[abbbeccc]	[a]	KEYBOARD SCALING (LEVEL) TYPE BIT1	0, 1
		[b]	DETUNE	0~7
		[c]	FREQUENCY	0~15
54	[aa0*****]	[a]	KEYBOARD SCALING (RATE) DEPTH	0~3
		[*]	ATTACK RATE	0~31
55	[abb*****]	[a]	MODULATOR/CARRIER FLAG	0, 1 (1=carrier)
		[b]	VELOCITY SENSITIVITY FOR AR	OP1 0~3
		[*]	DECAY 1 RATE	0~31
56	[aa0*****]	[a]	INHARMONIC FREQUENCY	0~3
		[*]	DECAY 2 RATE	0~31
57	[aaaabbbb]	[a]	SUSTAIN LEVEL	0~15
		[b]	RELEASE RATE	0~15 (0=Max. level)
58~5F			Same as OP1	OP2
60~67			do.	OP3
68~6F			do.	OP4
70~79			RESERVED	0
7A	[a*****]	[a]	POLY/MONO	0, 1 (1=MONO MODE)
		[*]	PORTAMENTO SPEED	0~127
7B	[0aaa*****]	[a]	INPUT CONTROLLER (PMD)	0~4※
		[*]	PITCHBENDER RANGE	0~12
7C~7F			RESERVED	0

※ 0=OFF, 1=TOUCH, 2=WHEEL, 3=BREATH, 4=FOOT

■ MIDI TRANSMIT DATA FORMAT

Normally the transmit function is not executed. When operation information such as dump request is received from the external source, or when the panel is so operated, the system exclusive message as described below is transmitted.

There are two main types of system exclusives that the FB-01 will transmit: data dumps and communication message.

Communication handshake message

There are three handshake messages that the FB-01 may transmit: ACK, NAK, and cancel. ACK indicates success. NAK indicates a check sum error, a data short error, a framing error, or an overrun error. Cancel indicates a memory protection error, and invalid number error (out of range or ROM area for save).

* Please see the Communication Message Table for details.

Status	11110000(F0H)
ID No.	01000011(43H)
Sub-status	0110nnnn(n = channel No.)
Message No.	0mmmmmm
EOX	11110111(F7H)

Communication handshake Message Tables

Message No.	Meaning	
m = 2 (0000 0010)	ACK	Completed
m = 3 (0000 0011)	NAK	An error occurred when data is received.
m = 4 (0000 0100)	Cancel	Impossible to execute for the following reason. a. Memory protect is ON. b. Memory No. is inappropriate.

Bulk data

This message dumps following 7 types of data according to the dump request or panel operation.

- ① Voice bank ϕ bulks data
Dumps the contents of the voice RAM 1.
- ② Voice bank x bulk data (x = 1 ~ 7)
Dumps the voice data for 48 voices of the bank specified by the bank No.
- ③ Current configuration
Dumps the contents of the configuration buffer.
- ④ Configuration memory
Dumps the contents of the configuration memory specified by the memory No.
- ⑤ 16 configuration memory
Dumps the contents of the configuraion RAM.

- ⑥ Unit ID number
Dumps the unit ID number.

Status	11110000(F0H)
ID No.	01000011(43H)
Sub-status	01110101(75H)
System No.	0000s s s s
Message No.	00000000(00H)
Operation No.	00000100(04H)
	00000000(00H)
Byte count	00000000(00H)
	00010000(10H)
Data	0ddddddd
	0ddddddd
Check sum	0eeeeeee
EOX	11110111(F7H)

* The data section is 16 bytes and the ASC II code of "YAMAHA COM FB-01" is sent.

- ⑦ One voice bulk data
This message dumps the data for one voice which is set in the voice buffer of the instrument specified by the instrument No.

* The data can be sent in the maximum length of 4096 bytes in which the 48 voices of bulk data is divided into 49 and the configuration RAM is divided into 16 before transmission. Each data transfer after the division has a byte count at its forefront and a check sum data at the end. These divided data blocks are transferred with a longer than 100msec. interval between them. (This interval is necessary when sending the data to the FB-01.)

NEW LSI DATA TABLE

μPD70008AC-6 (XA278001)

PIN NO.	NAME	I/O	FUNCTION	PIN NO.	NAME	I/O	FUNCTION
1	A11	O	} Address bus	40	A10	O	} Address bus
2	A12	O		39	A9	O	
3	A13	O		38	A8	O	
4	A14	O		37	A7	O	
5	A15	O		36	A6	O	
6	φ	I	Clock	35	A5	O	
7	D4	I/O	} Data bus	34	A4	O	
8	D3	I/O		33	A3	O	
9	D5	I/O		32	A2	O	
10	D6	I/O		31	A1	O	
11	+5		DC Supply (+5V)	30	A0	O	
12	D2	I/O	} Data bus	29	GND		DC Supply (0V)
13	D7	I/O		28	RFSH	O	Refresh
14	D0	I/O		27	M1	O	Machine Cycle one
15	D1	I/O		26	RESET	I	Reset
16	INT	I	Interrupt Request	25	BUSRQ	I	Bus Request
17	NMI	I	Non Maskable Interrupt	24	WAIT	I	Wait
18	HALT	O	Halt State	23	BUSAK	O	Bus Acknowledge
19	MREQ	O	Memory Request	22	WR	O	Write control
20	IORQ	O	Input/Output Request	21	RD	O	Read control

YM3012DAC (2-Channel serial input Floating D/A converter) iT301200

PIN NO.	NAME	I/O	FUNCTION	PIN NO.	NAME	I/O	FUNCTION
1	VDD	I	DC supply (+5V)	16	A.GND	I	Analog ground
2	CLOCK	I	Timing clock	15	RB	O	Bias-R
3	D.GND	I	Digital Ground	14	BC	I	Bias compensation
4	SD	I	Serial data input	13	MP	I	Middle point 1/2 VDD Bias
5	SAM2	I	Sample and hold (ch2)	12	A.OUT	O	Analog output to Buffer AMP
6	SAM1	I	Sample and hold (ch1)	11	COM	I	Ch1 ch2 analog SW common input
7	ICL	I	Initial clear	10	CH2	O	Sample and hold analog SW output (ch2)
8	A.GND	I	Analog Ground	9	CH1	O	Sample and hold analog SW output (ch1)

μPD71051C USART (Universal-Synchronous Asynchronous Receiver-Transmitter) XA996001

PIN NO.	NAME	I/O	FUNCTION	PIN NO.	NAME	I/O	FUNCTION
1	D2	I/O	} Data bus	28	D1	I/O	} Data bus
2	D3	I/O		27	D0	I/O	
3	RxD	I	Serial data in	26	V _{cc}		DC Voltage (+5V)
4	GND		Ground	25	RxC	I	Receiver clock
5	D4	I/O	} Data bus (A ₀ ~ A ₃)	24	DTR	O	Data terminal ready
6	D5	I/O		23	RTS	O	Request to Send
7	D6	I/O		22	DSR	I	Data set ready
8	D7	I/O		21	RST	I	Reset
9	TxC	I	Transmitter clock	20	CLK	I	Clock
10	WR	I	Write Control	19	TxD	O	Serial data out
11	CS	I	Chip select	18	TEMP	O	Transmitter empty
			Control/Data	17	CTS	I	Clear to Send
12	C/D	I	"H": Control/Status "L": Data	16	SYND	I/O	SYNC Detect/Break Detect
13	RD	I	Read Control	15	TxRDY	O	Transmitter ready
14	RxRDY	O	Receiver ready				

YM2164 OPP Operator (iT216400)

PIN NO.	NAME	I/O	FUNCTION	PIN NO.	NAME	I/O	FUNCTION
1	V _{ss}		GND	24	φM	I	Clock 3.58 MHz
2	IRQ	O	Interrupt data	23	φ1	I	Synchro pulse for DAC
3	IC	I	Initial clear	22	VDD	I	DC Supply (+5V)
4	AO	I	Address bus	21	S0	O	Tone signal data
5	WR	I	Write control	20	SH1	O	Sample and hold (Ch1)
6	RD	I	Read control	19	SH2	O	Sample and hold (Ch2)
7	CS	I	Chip Select	18	D7	I/O	} Data bus
8	CT1	O	Control data out 1	17	D6	I/O	
9	CT2	O	Control data out 2	16	D5	I/O	
10	D0	I/O	Data bus	15	D4	I/O	
11	V _{ss}		GND	14	D3	I/O	
12	D1	I/O	Data bus	13	D2	I/O	

■ PARTS LIST

FB-01 ELECTRONIC COMPONENTS

Ref. No.	Part No.	Description	品名	Remarks	ランク
*	 	Circuit Board	MAIN	MAINシート	60
*	 	Circuit Board	POWER	POWERシート	11
*	VB 39 75 00	Circuit Board	FRONT-SW	FRONT-SWシート	07
*	 	Circuit Board	MAIN	MAINシート	60
*	IC10 XA 27 80 01	IC	μ PD70008AC-6	IC CPU	09
*	IC7 IT 21 64 00	IC	YM-2164	IC OPP	16
*	IC8 XA 99 60 01	IC	μ PD71051C	IC USART	09
*	IC6 IT 30 12 00	IC	YM-3012	IC SUX DAC	08
*	IC19 IG 05 10 00	IC	TC40H004P	IC INV	03
*	IC2 IG 05 26 00	IC	HD74LS05P	IC INV	03
*	IC3 IG 14 22 00	IC	TC74HCU04P	IC INV	03
*	IC20 IR 00 04 00	IC	TC74HC04P	IC INV	03
*	IC16 IR 00 32 00	IC	TC74HC32P	IC OR	03
*	IC22 IR 00 02 00	IC	TC74HC02P	IC NOR	03
*	IC14 IR 00 74 00	IC	TC74HC74	IC DFF	04
*	IC21 IR 01 74 00	IC	TC74HC174	IC D. FF	05
*	IC18 IR 02 44 00	IC	TC74HC244	IC BUS. BUF	07
*	IC15 IR 01 38 00	IC	TC74HC138	IC DECO-8	05
*	IC9 IR 01 61 20	IC	μ PD74HC161C	IC CNT	04
*	IC1,4 IG 04 25 00	IC	NJM4556	IC OP AMP.	04
*	IC5 IG 07 66 00	IC	TL072CP	IC OP AMP.	04
*	IC12 XA 99 50 01	IC	μ PD4464C-15L	IC 64K SRAM	20
*	IC11 XB 46 00 01	IC	150NS	IC EPROM	12
*	TR4 IA 09 33 00	Transistor	2SA933S Q,R	トランジスタ	03
*	TR3 IA 09 99 00	Transistor	2SA999 D,E,F	トランジスタ	03
*	TR5 IC 18 15 30	Transistor	2SC1815 Y,GR	トランジスタ	03
*	→ IC 28 78 00	Transistor	2SC2878 A,B	トランジスタ	TR1,2,6,7
*	→ IF 00 34 50	Diode	1SS133	ダイオード	D1~7
*	ZD2 VB 60 69 00	Zener Diode	HZ4.2	ツェナーダイオード	01
*	ZD1 VB 61 83 00	Zener Diode	HZ3.6	ツェナーダイオード	01
*	FZ 00 41 70	Semiconductive Cera. Cap.	0.1 μ 16V	半導体セラコン	01
*	FG 21 11 80	Ceramic Cap.	18P 50V	セラコン	01
*	FG 21 13 30	Ceramic Cap.	33P 50V	セラコン	01
*	FG 21 13 90	Ceramic Cap.	39P 50V	セラコン	01
*	FG 21 15 60	Ceramic Cap.	56P 50V	セラコン	01
*	FG 21 18 20	Ceramic Cap.	82P 50V	セラコン	01
*	FG 21 21 20	Ceramic Cap.	120P 50V	セラコン	01
*	FG 21 21 80	Ceramic Cap.	180P 50V	セラコン	01
*	FG 44 41 00	Ceramic Cap.	0.01 μ 50V	セラコン	01
*	FJ 23 71 00	Electrolytic Cap.	10 μ 16V	ケミコン	01
*	FJ 23 81 00	Electrolytic Cap.	100 μ 16V	ケミコン	01
*	FJ 23 82 20	Electrolytic Cap.	220 μ 16V	ケミコン	01
*	FA 51 41 00	Mylar Cap.	0.01 μ 50V	マイラーコン	02
*	FA 15 31 00	Mylar Cap.	0.001 μ 50V	マイラーコン	02
*	FA 15 32 20	Mylar Cap.	0.0022 μ 50V	マイラーコン	02
*	FM 15 41 80	Mylar Cap.	0.018 μ 50V	マイラーコン	02
*	FM 54 71 00	Electrolytic Cap.	10 μ 16V	BPケミコン	02
*	FM 09 74 70	Electrolytic Cap.	47 μ 16V	BPケミコン	02
*	CA2 VB 00 66 80	Capacitor Array	100P 50V	コンデンサーアレイ	02
*	CA1 VB 44 04 00	Capacitor Array	1000P 50V	コンデンサーアレイ	02
*	HA 15 36 80	Carbon Resistor	6.8 Ω 1/4 J	カーボン抵抗	01

* : New Parts (NR)

ランク: Japan only

FB-01 ELECTRONIC COMPONENTS

Ref. No.	Part No.	Description	品名	Remarks	ランク
	HF 85 44 70	Carbon Resistor	47Ω 1/6 J	カーボン抵抗	01
	HF 85 45 60	Carbon Resistor	56Ω 1/6 J	カーボン抵抗	01
	HF 85 51 00	Carbon Resistor	100Ω 1/6 J	カーボン抵抗	01
	HF 85 52 20	Carbon Resistor	220Ω 1/6 J	カーボン抵抗	01
	HF 85 52 70	Carbon Resistor	270Ω 1/6 J	カーボン抵抗	01
	HF 85 53 30	Carbon Resistor	330Ω 1/6 J	カーボン抵抗	01
	HF 85 54 70	Carbon Resistor	470Ω 1/6 J	カーボン抵抗	01
	HF 85 55 60	Carbon Resistor	560Ω 1/6 J	カーボン抵抗	01
	HJ 35 61 00	Carbon Resistor	1kΩ 1/4 J	カーボン抵抗	01
	HF 85 61 00	Carbon Resistor	1kΩ 1/6 J	カーボン抵抗	01
	HF 85 61 20	Carbon Resistor	1.2kΩ 1/6 J	カーボン抵抗	01
	HF 85 62 20	Carbon Resistor	2.2kΩ 1/6 J	カーボン抵抗	01
	HF 85 63 30	Carbon Resistor	3.3kΩ 1/6 J	カーボン抵抗	01
	HF 85 64 70	Carbon Resistor	4.7kΩ 1/6 J	カーボン抵抗	01
	HF 85 68 20	Carbon Resistor	8.2kΩ 1/6 J	カーボン抵抗	01
	HF 85 71 00	Carbon Resistor	10kΩ 1/6 J	カーボン抵抗	01
	HF 85 72 20	Carbon Resistor	22kΩ J/6 J	カーボン抵抗	01
	HF 85 81 00	Carbon Resistor	100kΩ 1/6 J	カーボン抵抗	01
	HF 85 91 00	Carbon Resistor	1MΩ 1/6 J	カーボン抵抗	01
	VB 60 79 00	Metal Film Resistor	330Ω 1/6 F	金属皮膜抵抗	
	HU 57 53 90	Metal Film Resistor	390Ω 1/6 F	金属皮膜抵抗	02
	HU 57 62 40	Metal Film Resistor	2.4kΩ 1/6 F	金属皮膜抵抗	02
	HU 57 64 70	Metal Film Resistor	4.7kΩ 1/6 F	金属皮膜抵抗	02
→	HZ 00 47 30	Resistor Array	RML8	抵抗アレイ	RA1~4
RA5	VA 09 22 00	Resistor Array	RMLS8-223J	抵抗アレイ	01
X1	QU 00 05 00	Quartz Crystal Unit	4MHz	水晶振動子	05
X2	QU 00 77 00	Ceramic Resonator	12MHz	セラミック振動子	03
PC1	VA 92 86 00	Photo Coupler	PC910	フォトカブラ	06
BATT	PC 90 00 30	Lithium Battery	CR2032T	リチウム電池	04
LF6	FZ 00 69 70	EMI Filter	Y223NB	EMIフィルター	02
→	GE 30 06 70	Ferrite Bead	BL02RN2 R62T2	フェライトビーズ	LF4,7,8,10,11
→	VC 54 27 00	EMI Coil	HFN0051	EMIコイル(LF1,12,13)	FB-01G only
→	VC 54 32 00	EMI Coil	HFN0071	EMIコイル(LF14)	FB-01G only
SW1	VA 10 16 00	Slide Switch	SSS522	スライドSW	02
→	LB 20 23 30	Phone Jack	HLJ0521	ホーンジャック	02
→	VC 57 40 00	Connector	5P TCS4450-01	DINコネクタ	JK3,4,5
LED	LB 91 80 30	Base Post Connector	3P I-TYPE	ベースツキポスト	01
PW	LB 91 80 60	Base Post Connector	6P I-TYPE	ベースツキポスト	01
SW	LB 91 81 00	Base Post Connector	10P I-TYPE	ベースツキポスト	02
LF5	VB 41 52 00	Cable	ESD-R-14A	束線キット	06
S1	VC 57 34 00	Earth Cord		アースコード	
	VC 57 34 00	Circuit Board	POWER	POWERシート	11
TR2	IG 07 56 00	IC	NJM78M05A 5V	IC	03
TR1	IG 14 76 00	IC	NJM7805A 5V	IC	04
TR3	XB 11 60 01	IC	MJM79M05A -5V	IC	04
D1,2	IH 00 05 90	Diode	10E-1	ダイオード	01
D3	IH 00 08 80	Diode Stack	STWB20	ダイオードスタック	03
	FZ 00 41 10	Semiconductive Cera. Cap.	0.1μ 16V	半導体セラコン	01
	FJ 23 81 00	Electrolytic Cap.	100μ 16V	ケミコン	01
	FJ 14 84 70	Electrolytic Cap.	470μ 16V	ケミコン	02
	FZ 00 42 80	Electrolytic Cap.	4700μ 16V	ケミコン	05
	Fi 38 32 20	Cap Special Ppec	DE7100/2200-400	2200P/400V	FB-01G only

* : New Parts (NR)

ランク: Japan only

FB-01 EXTERNAL COMPONENTS

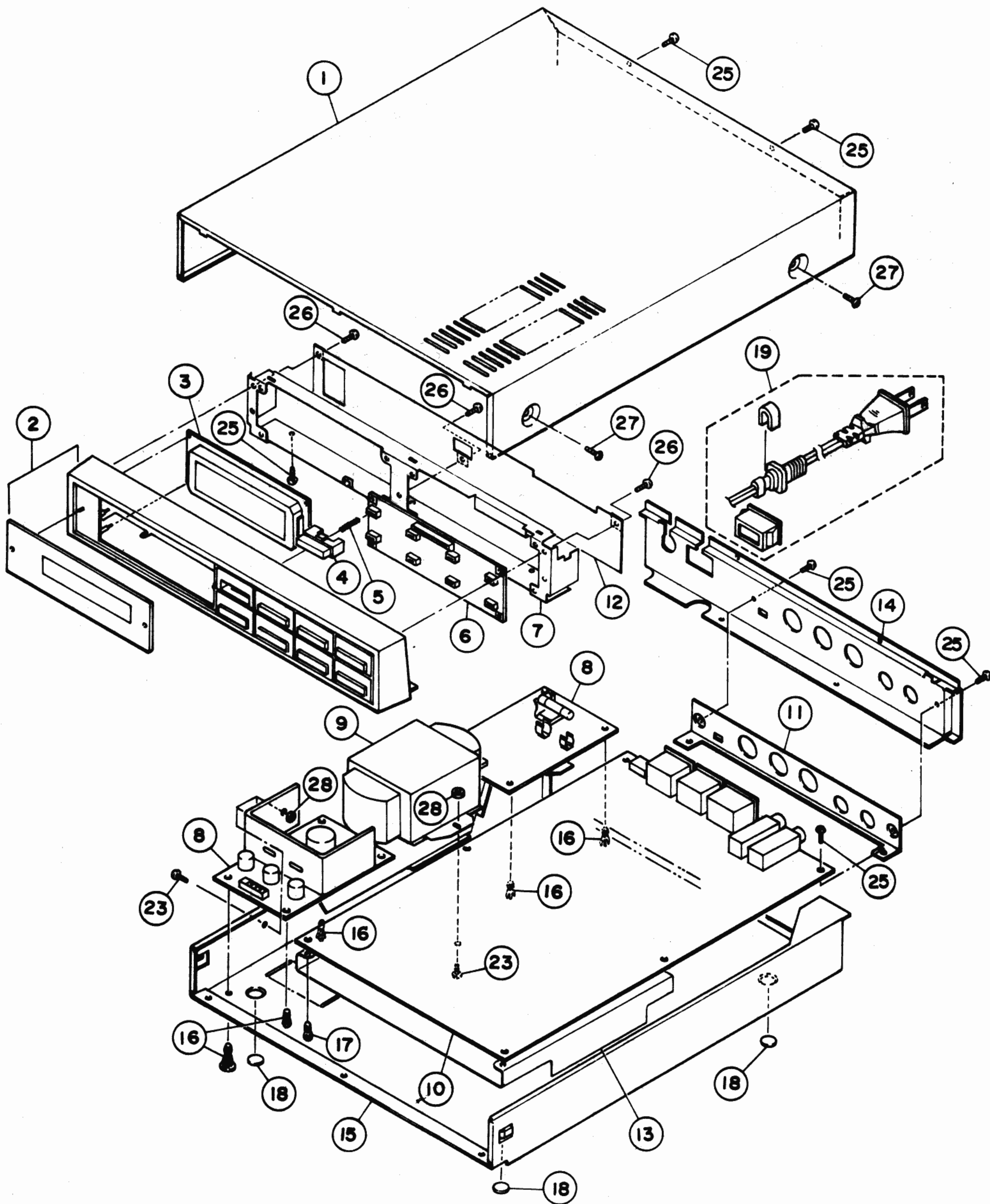

Ref. No.	Part No.	Description	品名	Remarks	ランク
* 1	VB 44 96 00	Top Case	トップケース		
* 2	VB 51 98 00	Front Panel Assembly	フロントパネルAss'y	J, F, G	
* 2	VB 98 45 00	Front Panel Assembly	フロントパネルAss'y	U, C	
* 3	VB 44 81 00	LCD Assembly	LCD Ass'y		
* 4	VB 45 06 00	Switch Buttom	スイッチボタン	J, F, G	
* 4	VB 80 75 00	Switch Buttom	スイッチボタン	U, C	
* 5	VB 45 11 00	Switch Spring	スイッチスプリング		
* 6	VB 39 75 00	Circuit Board	FRONT-SW	FRONT-SWシート	
* 7	VB 45 02 00	Sub Panel	サブパネル		
* 8	VB 37 99 00	Circuit Board	POWER	POWERシート	J
* 8	VB 38 00 00	Circuit Board	POWER	POWERシート	U
* 8	VC 54 14 00	Circuit Board	POWER	POWERシート	C
* 8	VB 38 01 00	Circuit Board	POWER	POWERシート	F
* 8	VC 54 36 00	Circuit Board	POWER	POWERシート	G
* 9	XB 07 50 01	Power Transformer	電源トランス	J	
* 9	XB 49 50 01	Power Transformer	電源トランス	U	
* 9	XB 97 50 01	Power Transformer	電源トランス	C	
* 9	XB 49 20 01	Power Transformer	電源トランス	F, G	
* 10	VB 34 87 00	Circuit Board	Main	Mainシート	J
* 10	VC 57 23 00	Circuit Board	Main	Mainシート	U, C, F
* 10	VC 57 24 00	Circuit Board	Main	Mainシート	G
* 11	VB 45 03 00	Main Board Stay		メインボードステー	
* 12	VB 49 27 00	LCD Shield		LCDシールド	J, F, G
* 12	VC 68 45 00	LCD Shield		LCDシールド	U, C
* 13	VB 49 28 00	Main Board Earth		メインボードアース	U, C, G
* 14	VB 44 97 00	Rear Panel		リアパネル	J
* 14	VB 98 40 00	Rear Panel		リアパネル	U
* 14	VC 35 23 00	Rear Panel		リアパネル	C
* 14	VB 98 42 00	Rear Panel		リアパネル	F
* 14	VC 11 54 00	Rear Panel		リアパネル	G
* 15	VB 45 00 00	Bottom Case		ボトムケース	J, F, G
* 15	VC 46 09 00	Bottom Case		ボトムケース	U, C
* 16	VB 45 14 00	Spacer 6R		ロッキングカードスパーサ	
* 17	VB 45 13 00	Spacer 8R		ロッキングカードスパーサ	J, F
* 18	CB 04 37 50	Leg Foot	BL	ゴム脚	
* 19	VB 44 94 00	AC Inlet Assembly		電源コードAss'y	J
* 19	VC 29 66 00	AC Inlet Assembly		電源コードAss'y	U
* 19	VC 35 37 00	AC Inlet Assembly		電源コードAss'y	C
* 19	VB 98 29 00	AC Inlet Assembly		電源コードAss'y	F, G
* 20	VC 36 08 00	Polypropylene Film	ポリエステルフィルム	インシュレータ0.35t	F, G
* 21	VC 46 10 00	Fuse Protector		ヒューズプロテクタ	F, G
* 22	VC 36 07 00	Fuse Label Plate		ヒューズラベルプレート	U, C
23	EA 33 00 66	Pan Head Screw	3.0×6 FCM3BL	ナベ小ネジ	PACK 01
24	ED 03 01 26	Bind Screw	3.0×12	バインドコネジ	
25	EI 33 00 66	Bind Tapping Screw	3.0×6 ZMC2BL	バインドタッピングネジ	PACK
26	EI 03 00 86	Bind Tapping Screw	3.0×8 ZMC2Y	バインドタッピングネジ	PACK 01
27	EI 34 00 66	Bind Tapping Screw	4.0×6 ZMC2BL	バインドタッピングネジ	PACK 01
28	EV 10 30 36	Hexagonal Nut	φ3 ZMC2BL	六角ナット	01

* : New Parts (NR)

ランク: Japan only

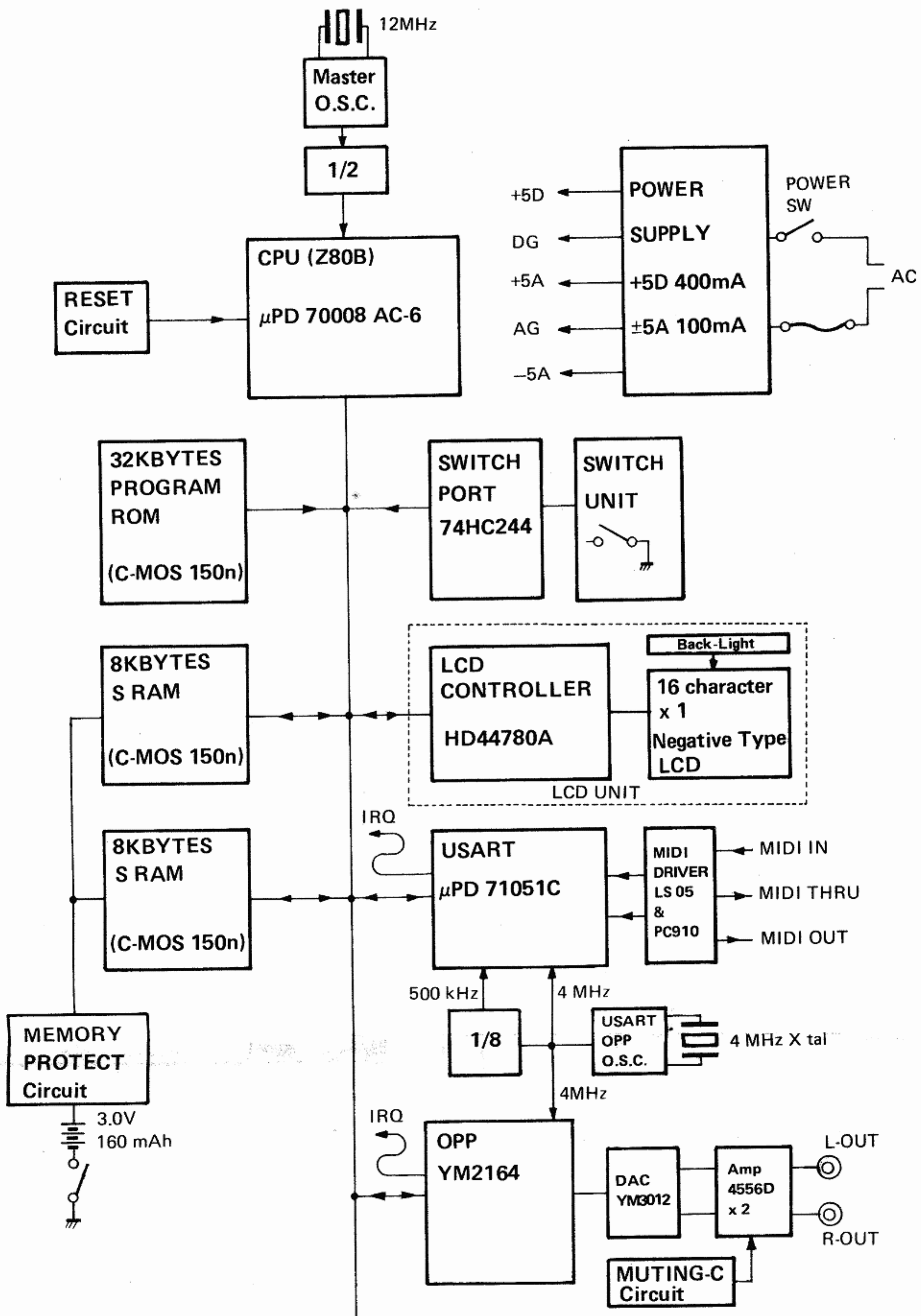

■ FB-01 POWER CIRCUIT BOARD

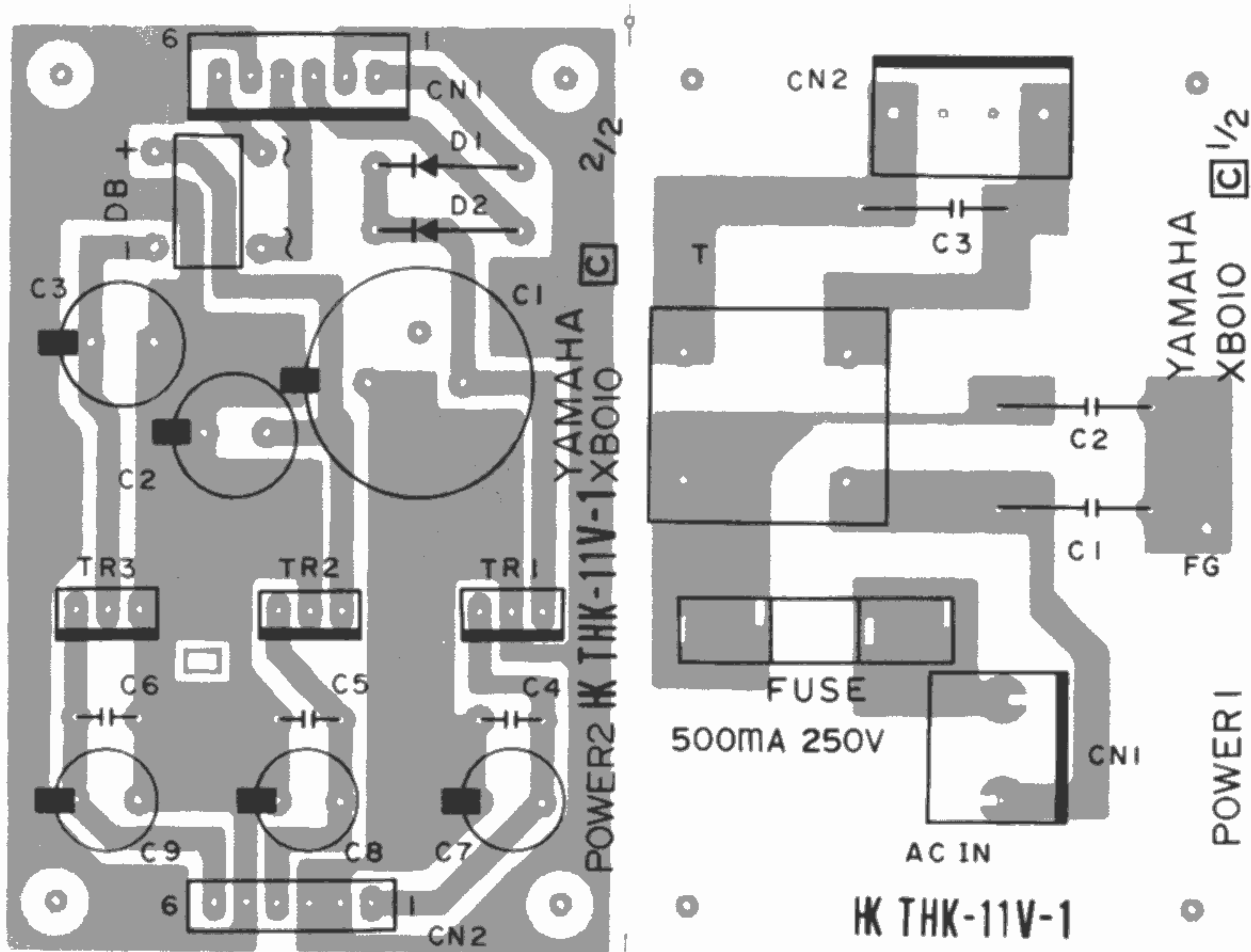

■ FB-01 SWITCH CIRCUIT BOARD

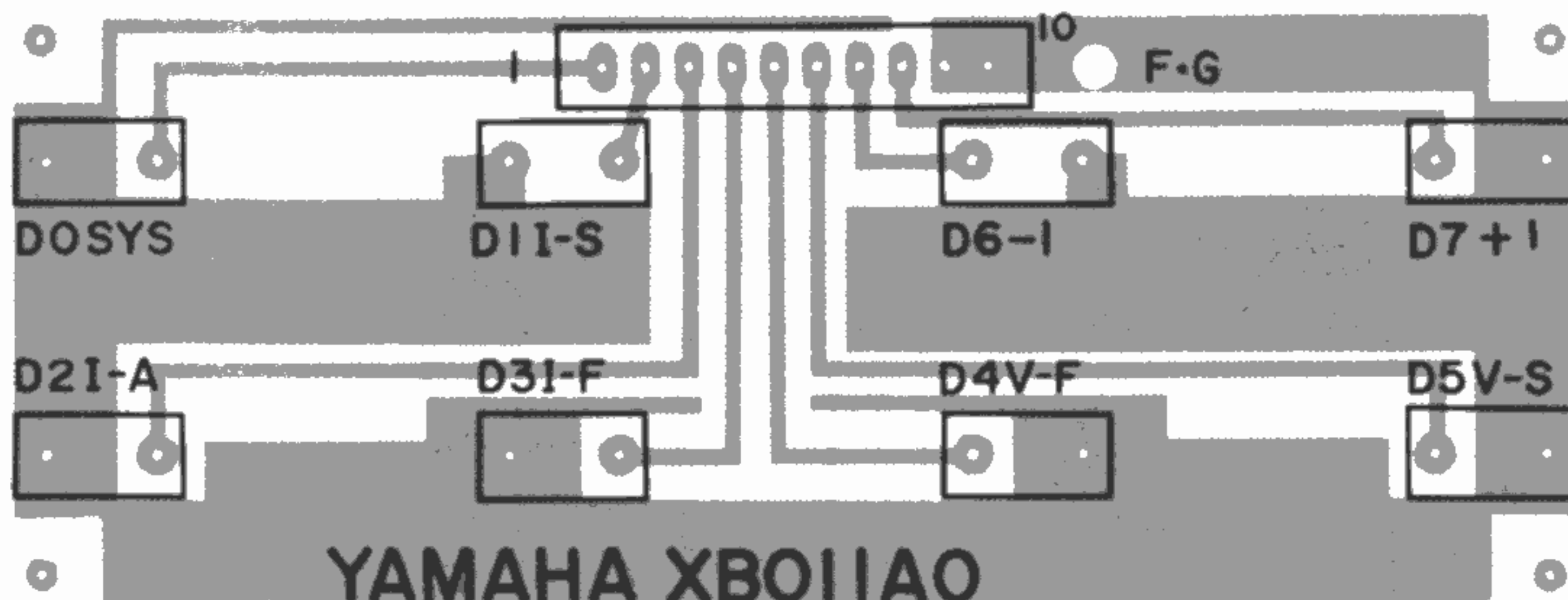

FB-01 MAIN CIRCUIT BOARD

VC572400(G)

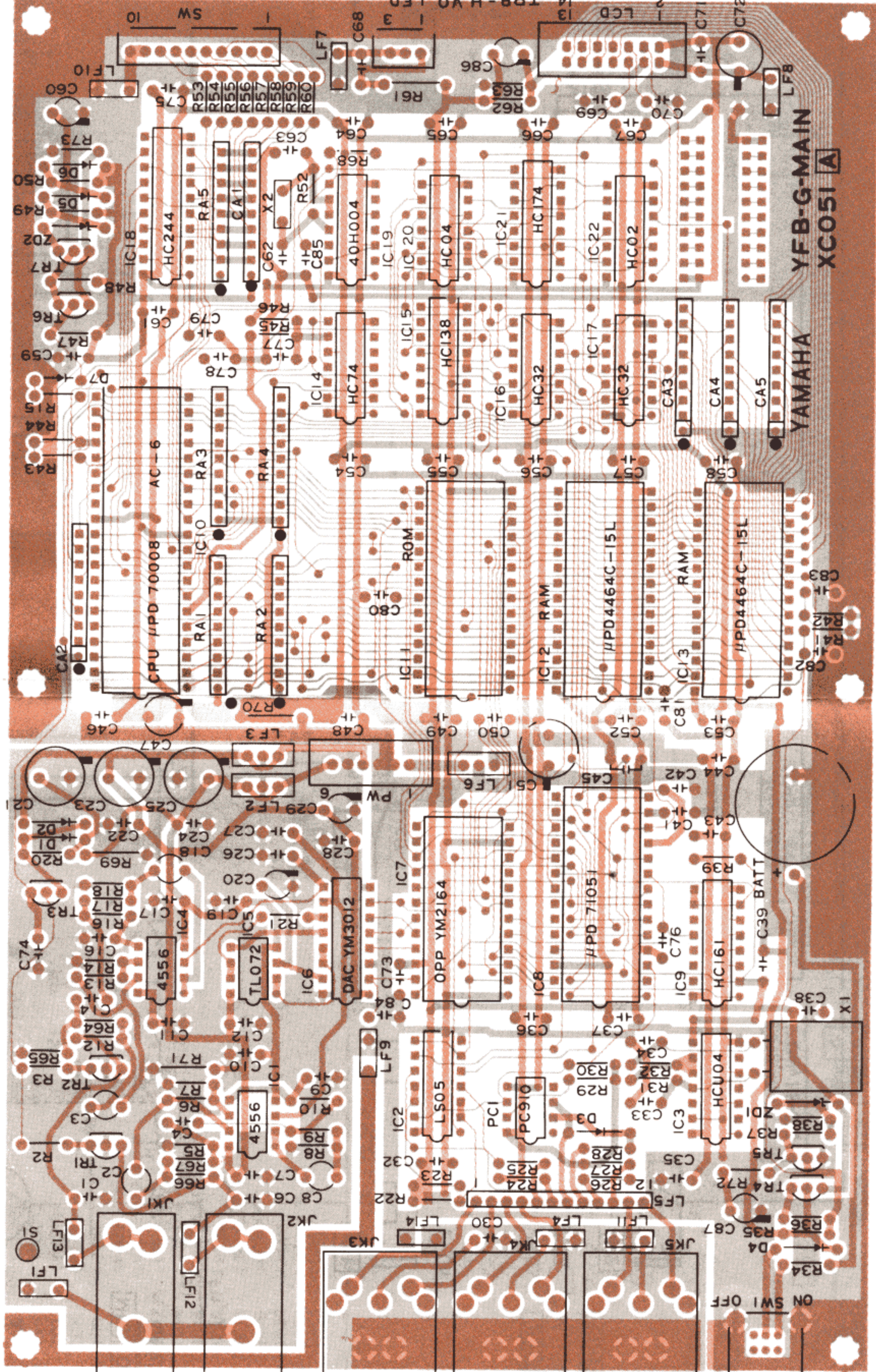

FB-01 OVERALL CIRCUIT DIAGRAM

SW FUNCTION TABLE	
SW 1	SYSTEM
SW 2	Ins-Setl
SW 3	Ins-Assignt
SW 4	Ins-Func
SW 5	Voice-Func
SW 6	Voice-Setl
SW 7	-1/NO
SW 8	+1/YES

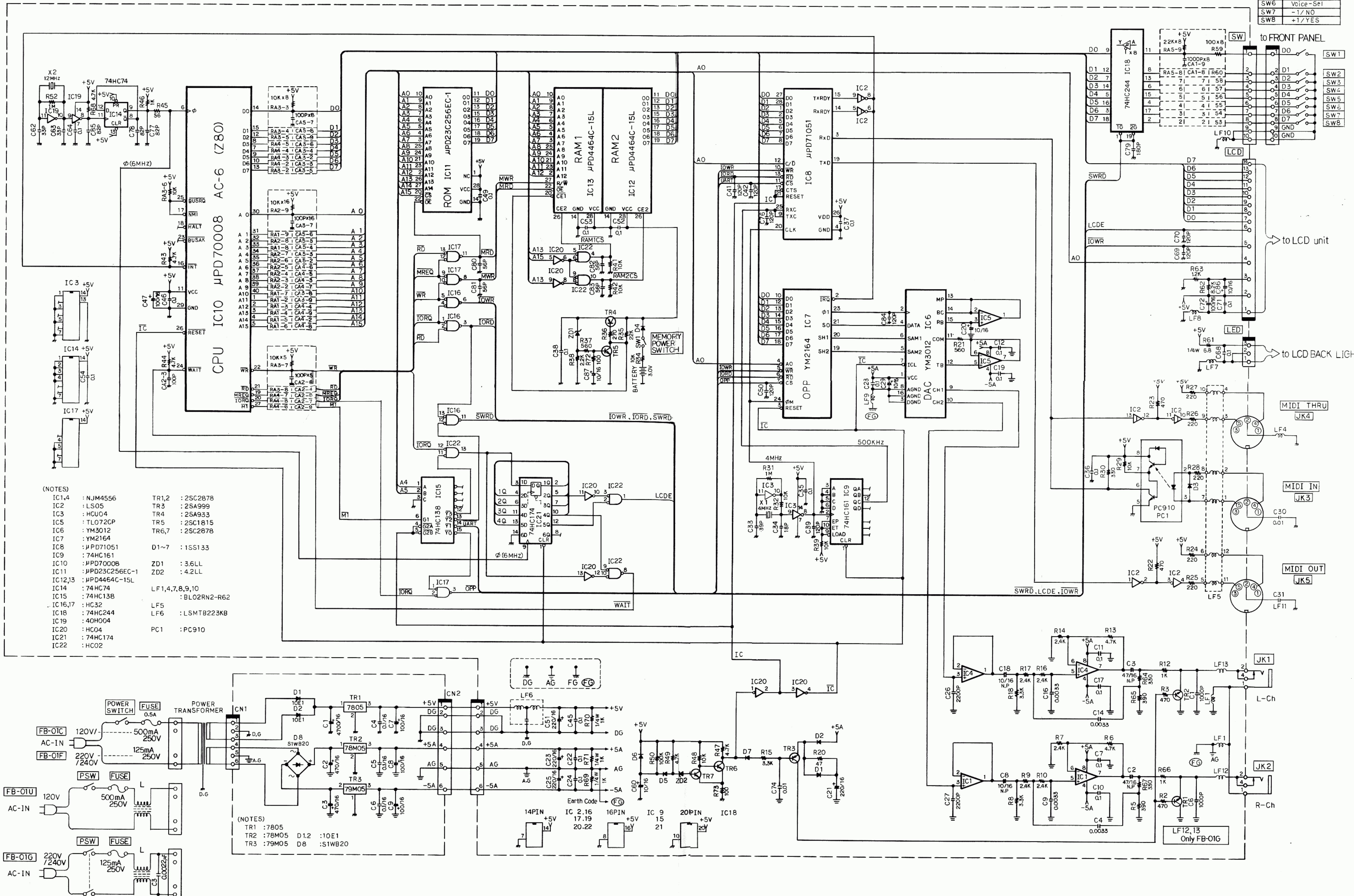

- (NOTES)
- | | |
|------------------------|-------------------|
| IC1,4 : NJM4556 | TR1,2 : 2SC2878 |
| IC2 : LS05 | TR3 : 2SA999 |
| IC3 : HCU04 | TR4 : 2SA933 |
| IC5 : TL072CP | TR5 : 2SC1815 |
| IC6 : YM3012 | TR6,7 : 2SC2878 |
| IC7 : YM2164 | D1~7 : 1SS133 |
| IC8 : MPD71051 | ZD1 : 3.6LL |
| IC9 : 74HC161 | ZD2 : 4.2LL |
| IC10 : MPD70008 | LF1,4,7,8,9,10 |
| IC11 : MPD23C256EC-1 | LF5 : BLO2RN2-R62 |
| IC12,13 : MPD4464C-15L | LF6 : LSMTB223KB |
| IC14 : 74HC74 | PC1 : PC910 |
| IC15 : 74HC138 | |
| IC16,17 : HC32 | |
| IC18 : 74HC244 | |
| IC19 : 40H004 | |
| IC20 : HC04 | |
| IC21 : 74HC174 | |
| IC22 : HC02 | |

- (NOTES)
- | | |
|-------------|-------------|
| TR1 : 7805 | D1,2 : 10E1 |
| TR2 : 78M05 | D8 : S1WB20 |
| TR3 : 79M05 | |