

# SV-805

## RS 232 INTERFACE USER'S MANUAL

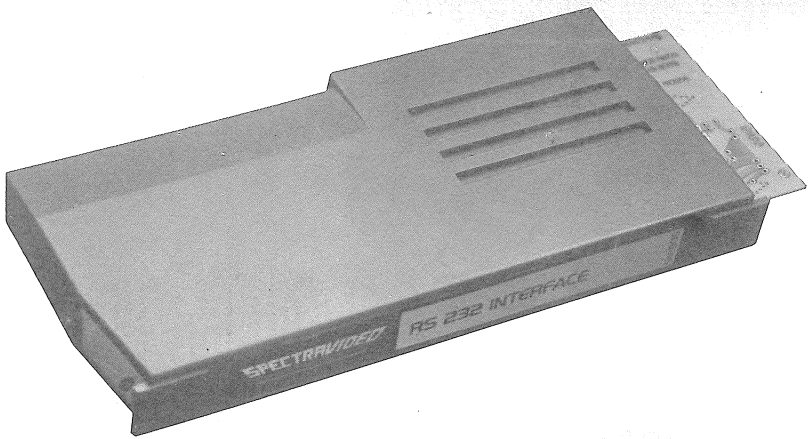

**SPECTRAVIDEO**<sup>TM</sup>



# **SPECTRAVIDEO'S USER'S MANUAL STATEMENT**

## **WARNING:**

This equipment generates, uses, and can radiate radio frequency energy and if not installed and used in accordance with the instruction manual, may cause interference to radio communications. It has been tested and found to comply with the limits for a Class A computing device pursuant to subpart J of Part 15 of FCC Rules, which are designed to provide reasonable protection against such interference when operated in a commercial environment. Operation of this equipment in a residential area is likely to cause interference in which case the user at his own expense will be required to take whatever measures may be required to correct the interference.



# Introduction

Spectravideo's RS232 card is specially for use with the SV-601/SV-605 Super Expander in connection to the SV318 or SV328 basic unit. This card allows the user to connect the SV-318 or SV-328 to any data communication equipment RS232 standard. With the use of the card the user may hook up the SV-318/328 computer to a Modem, teletype equipment, printer etc. Read this instruction manual thoroughly to become familiar with the RS232 Interface card. It is your guide to proper installation and operation.

Published by  
SPECTRAVIDEO INTERNATIONAL LTD.

Second Edition  
First Printing 1983  
Printed in Hong Kong  
Copyright © 1983 by Spectravideo International Ltd. All rights reserved

Every effort has been made to supply complete and accurate information in this manual. Spectravideo International Ltd. reserves the right to change Technical Specifications and Characteristics at any time without notice.

No part of this publication may be stored in a retrieval system, transmitted, or reproduced in any way, including but not limited to photocopy, magnetic or other record, without the prior agreement and written permission from Spectravideo International Ltd.

**SV-805-UM-02**

# SPECTRAVIDEO SV805 RS232 Interface Card INSTRUCTION MANUAL

## CONTENTS

PAGE

|                                   |    |
|-----------------------------------|----|
| 1. Accessories .....              | 2  |
| 2. Layout .....                   | 2  |
| 3. Main Features .....            | 3  |
| 4. Connections/Power Supply ..... | 3  |
| 5. Operations .....               | 4  |
| 6. Cautions .....                 | 7  |
| 7. Maintenance .....              | 7  |
| 8. I/O Assignment .....           | 7  |
| 9. Specifications .....           | 11 |

## 1. Accessories

The package of SV-805 RS232 Interface Card should contain the following items:

- (A) The RS232 Interface card you have purchased
- (B) Instruction Manual

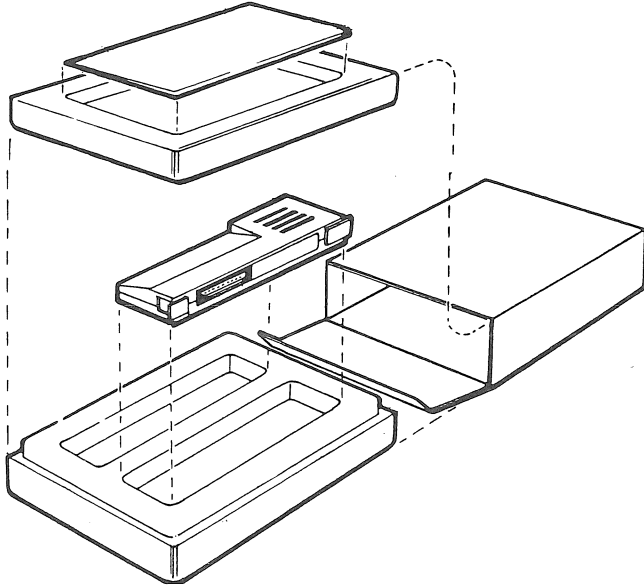

## 2. Layout

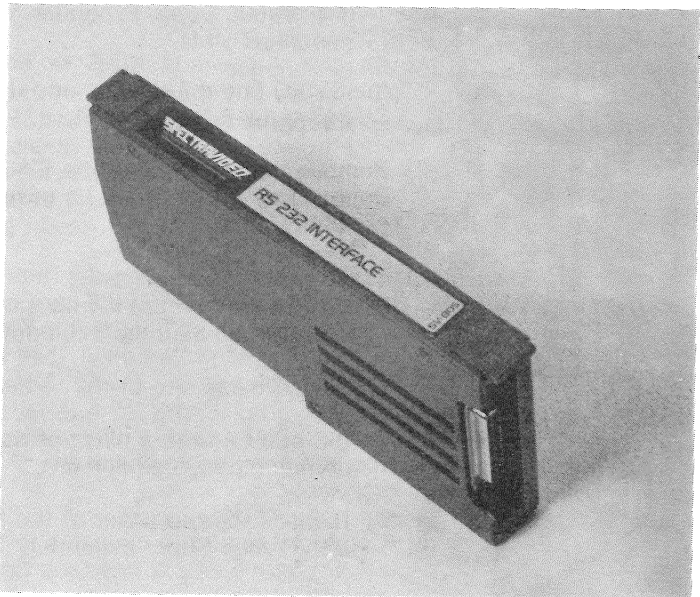

### 3. Main features

- (A) The Electronic Industrial Association standard RS232 was specifically designed to define the electrical characteristics for an interface between a piece of data terminal equipment and a piece of data communication equipment, hence, SV805 provides a link between you SV-318/328 and a modem, teletype equipment, printer etc.
- (B) A LED Indicator on the front of the card shows you that it is in operation.
- (C) The card is designed for ease of insertion and for durability.
- (D) Battery free as power is supplied by the SV601/SV605 Expander Unit.

### 4. Connections

The following is a guide to the proper hook-up procedures for the SV805-RS232 Interface Card.

- (A) Be sure all power is "OFF" on both the SV601/SV605 Super Expander and the SV-318 or SV-328 basic unit.
- (B) Remove the top cover of the SV-601/SV605 Super Expander to reveal its peripheral slots.
- (C) For SV-601 these slots are numbered 0 through 6 from left to right. Plug the card into any slot except #6 (this slot is for the floppy disk controller only). For SV-605, the slots are numbered 0 through 5. Plug the card into any slot. Insert card into slot gently. Do not force.
- (D) Be certain the card is fully seated in the slot and double check all connections.
- (E) Connect one end of the cable to the socket on the RS232 Interface Card and the other end to a piece of data communication equipment.
- (F) Replace the top cover of the SV-601/SV605 Super Expander.

## Power Supply

- (G) All the peripheral and interface cards that attach to the SV601/SV605 Super Expander, including the SV805-RS232 Interface card described in this manual, receive their power directly from the expander.

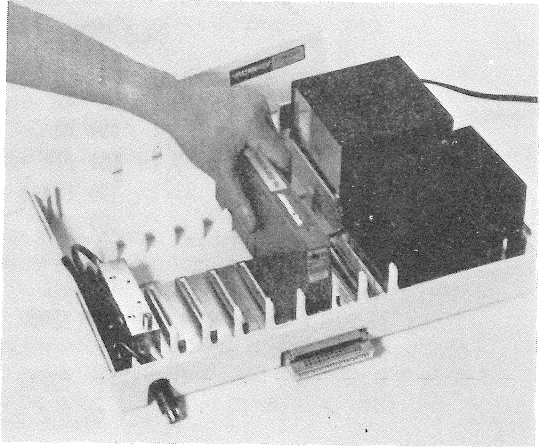

## 5. Operation

The SV-805 RS232 Interface card is used to interface various communication devices such as printers. When the SV-805-RS232 Interface card is used under CP/M, the baud rates are selectable. All data equipment should be set to the same baud rate.

- (A) Connect the cable of the RS232 card installed in one Super Expander unit to another communication equipment.
- (B) After inserted the CP/M diskette in the disk drive, and type DIR to check the diskette directory, then the list of filenames will appear on the screen. The RS232 driver program which locates in the CP/M diskette, appears as IRS232 in the directory.
- (C) The prompt A> denotes CP/M is ready and just type in the word IRS232 to initialize the program.
- (D) The list of Baud Rate followed by the Word Length, Stop Bits and Parity Bit will display on the screen as below:

RS-232 INITIALIZATION PROGRAM

BY SPECTRAVIDEO

BAUD RATE :

<A> 50    <I> 1800  
<B> 75    <J> 2000  
<C> 110   <K> 2400  
<D> 134.5 <L> 3600  
<E> 150   <M> 4800  
<F> 300   <N> 7200  
<G> 600   <O> 9600  
<H> 1200

(Default 1200)

select (A,B,C,D....O) :

(Default 8)

WORD LENGTH ( 5,6,7 or 8 ) :

(Default 2)

STOP BITS (1,2) :

(Default Odd)

PARITY BIT ( "O"dd, "E"ven, "N"one ) :

CONFIRM ( Yes or No ) :

- (E) The baud rate represents the no. of bits transferred per second. Hence the fastest baud rate is 9600 and the slowest baud rate is 50. The baud rate selected should be the same as the equipment to be communicated.
- (F) Enter the code corresponding to the desired baud rate. The default value of baud rate, word length, stop bits and parity bit are "H", "8", "2" and "O" respectively. If you do not want to select, just press ENTER, the computer will fill in the default values for you.



- (G) To confirm the above inputs, press Y to represent Yes or just ENTER, otherwise press N to represent No and the selection menu will be repeated.
- (H) The above initialization must be done for the RS232 card installed before transmit and/or receive.

### Typical Examples

To transfer a file in the SV-318 (transmitter computer) to another computer (receiver computer), assume that the receiver computer is another SV-318 system.

- (A) Insert the CP/M diskettes with RS232 drive program into both computers.
- (B) Initialize both computers with RS232 drive program as described above. Be sure both computers are set to have the same data format and baud rate.
- (C) The transferring of data from one diskette in the transmitter computer to another diskette in the receiver computer will function by typing RECV to the receiver computer. After pressing ENTER, wait for the message, "RECEIVING FROM RS232....."  
The prompt sign "A<:" will appear on the screen.
- (D) Then type XMIT and the filename (e.g. XMIT.MAC) to be transferred to the transmitter computer. After pressing ENTER, the computer will display, ".....TRANSMITTING  
FILE(S).....>RS232"
- (E) Both screens of the two computers will display the filename and the transferring block no. It shows that it is in operation and the total no. of bits in that file when it stops.
- (F) When the transferring process is complete, the word "FINISH" will appear on both screens and get back to the CP/M by pressing CTRL and STOP simultaneously.

- (G) One point to note is that if you press CTRL and STOP during transmission at the transmitter computer, you will break the communication link. The receiver computer cannot close the file and it will contain nothing. Hence you must press CTRL and STOP at the receiver computer and transfer again.

## 6. Cautions

Proper caution should be observed when handling the SV-805 RS232 Interface card and all other interface.

- (A) Never remove or insert an RS232 Interface card or any peripheral card with the power "On". This could cause serious damage to your system.
- (B) Never remove the protective casing surrounding the printed circuit board.
- (C) Never bang or drop the card. This could cause irreparable damage to the circuit board.

## 7. Maintenance

The performance of preventive maintenance on any Spectravideo card is essential to the life of the card. The following is a description of preventive maintenance you may perform on your RS232 Interface card

- (A) Use a cleaning solvent, preferably freon based, to clean the bus fingers located at the bottom of the card.
- (B) The use of a wire brush is also recommended when cleaning bus fingers.
- (C) Never smoke, eat or drink anything near the cartridge. Particles of food and dust can get lodged in the printed circuit board, affecting performance and perhaps causing damage.
- (D) When not in use, store card in a dark place well away from sunlight.

## 8. I/O Assignment

| PIN | NAME   | PIN | NAME    |
|-----|--------|-----|---------|
| 1   | +5V    | 2   | CNTRL2  |
| 3   | +12V   | 4   | -12V    |
| 5   | CNTRL1 | 6   | WAIT    |
| 7   | RST    | 8   | CPU CLK |
| 9   | A15    | 10  | A14     |
| 11  | A13    | 12  | A12     |
| 13  | A11    | 14  | A10     |
| 15  | A9     | 16  | A8      |
| 17  | A7     | 18  | A6      |
| 19  | A5     | 20  | A4      |
| 21  | A3     | 22  | A2      |
| 23  | A1     | 24  | A0      |
| 25  | RFSH   | 26  | EXCSR   |
| 27  | M1     | 28  | EXCSW   |
| 29  | WR     | 30  | MREQ    |
| 31  | IORQ   | 32  | RD      |
| 33  | D0     | 34  | D1      |
| 35  | D2     | 36  | D3      |
| 37  | D4     | 38  | D5      |
| 39  | D6     | 40  | D7      |
| 41  | CSOUND | 42  | INT     |
| 43  | RAMDIS | 44  | ROMDIS  |
| 45  | BK32   | 46  | BK31    |
| 47  | BK22   | 48  | BK21    |
| 49  | GND    | 50  | GND     |

**\* SV-318/328 EXPANDER BUS SIGNAL DESCRIPTION \***

PIN: NAME: I/O: DESCRIPTION:

|      |                            |   |   |
|------|----------------------------|---|---|
| 1    | +5V                        | O | +5V power supply, 300mA current is available for all peripheral cards.  |
| 2    | $\overline{\text{CNTRL2}}$ | I | Spectravideo game adapter for Coleco™ games. CONTROL signal (normally held HIGH by a 3.3K ohm resistor). This signal, when the game adapter is in use, controls the data transfer between the CPU and the adapter during the external I/O addressing. |
| 3    | +12V                       | O | +12V power supply. Maximum current is 100mA for all peripheral cards.   |
| 4    | -12V                       | O | -12V power supply. Maximun current is 50mA for all peripheral cards.  |
| 5    | $\overline{\text{CNTRL1}}$ | I | Spectravideo game adaptor for Coleco™ games CONTROL signal (normally held HIGH by 1K ohm resistor). This signal, when pulled LOW (i.e. when the adaptor is in use), disables all internal (i.e. SV-318/328) I/O address decoding, and inverses A15.   |
| 6    | $\overline{\text{WAIT}}$   | I | Indicates to Z80A CPU that the addressed memory or I/O devices are not ready for data transfer.   |
| 7    | $\overline{\text{RST}}$    | I | When this signal is pulled LOW the CPU begins a RESET cycle. During this RESET cycle, the address and data bus enter a high impedance state and the control signals enter the inactive state.   |
| 8    | CPUCLK                     | O | Buffered system clock of frequency 3.58 MHz.  |
| 9-24 | A15-A0                     |   | Buffered ADDRESS BUS. This is a 16-bit address bus providing addresses for memory data exchange and I/O device data exchange.   |
| 25   | $\overline{\text{RFSH}}$   | O | Buffered REFRESH signal for the dynamic RAM expanders only. This signal indicates that the lower 7 bits of the address bus contain a refresh address for the dynamic RAM.   |
| 26   | $\overline{\text{EXCSR}}$  | I | This is the external CPU-from-VDP READ select signal, and is used by Spectravideo game adaptor for Coleco™ games only.  |
| 27   | $\overline{\text{M1}}$     | O | Buffered MACHNINE ONE CYCLE signal. This signal indicates that OP code fetch cycle is the current machine cycle.  |
| 28   | $\overline{\text{EXCSW}}$  | I | This is the external CPU-to-VDP WRITE select signal, and is used by Spectravideo game adaptor for Coleco™ games only.   |
| 29   | $\overline{\text{WR}}$     | O | Buffered WRITE signal. This signal indicates  |

|       |                            |   |  |
|-------|----------------------------|---|--|
|       |                            |   | that the CPU data bus holds valid data for storage in the addressed memory or I/O device.  |
| 30    | $\overline{\text{MREQ}}$   | O | Buffered MEMORY REQUEST signal. This signal indicates when the address bus is holding a valid memory address.  |
| 31    | $\overline{\text{IORQ}}$   | O | Buffered INPUT/OUTPUT REQUEST signal. This signal indicates the lower 8 bits of the address bus are holding a valid I/O device address, and is at HIGH state (i.e. inactive) during the INTERRUPT cycle.                             |
| 32    | $\overline{\text{RD}}$     | O | Buffered READ signal. This signal indicates that the Z80A CPU is wanting to read data from memory or an I/O device.  |
| 33-40 | D0-D7                      |   | Buffered bidirectional DATA bus. This is an 8-bit bidirectional data bus for data exchange between memory and I/O devices.   |
| 41    | CSOUND                     | I | AUDIO input signal from the Spectravideo game adaptor for Coleco™ games.   |
| 42    | $\overline{\text{INT}}$    | I | Generated by I/O devices to request interrupt to Z80A CPU.   |
| 43    | $\overline{\text{RAMDIS}}$ | I | Pulling this signal LOW disables the SV-318/328 user RAM. This line is held high by a 1K ohm resistor to +5V.  |
| 44    | $\overline{\text{ROMDIS}}$ | I | Pulling this signal LOW disables the SV-318/328 BASIC ROM on board.  |
| 45    | $\overline{\text{BK32}}$   | O | Buffered MEMORY BANK CONTROL signal. Pulling this signal LOW enables the bank 32 portion of the memory (32K, Addr. — 8000H-FFFFH), and disables the user RAM on board through the RAMDIS signal.                                     |
| 46    | $\overline{\text{BK31}}$   | O | Buffered MEMORY BANK CONTROL signal. Pulling this signal LOW enables the bank 31 portion of the memory (32K, Addr. — 0000H-7FFFH), and disables the BASIC ROM on board through the ROMDIS signal.                                    |
| 47    | $\overline{\text{BK22}}$   | O | Buffered MEMORY BANK CONTROL signal. Pulling this signal LOW enables the bank 22 portion of the memory (32K, Addr. — 8000H-FFFFH), and disables the user RAM on board through the RAMDIS signal.                                     |
| 48    | $\overline{\text{BK21}}$   | O | Buffered MEMORY BANK CONTROL signal. Pulling this signal LOW enables the bank 21 portion of the memory (32K, Addr. — 0000H-7FFFH) which is the lower portion of SV-328 user addressable memory, and disables the BASIC ROM on board. |
| 49-50 | GND                        |   | System electrical ground.  |

## 9. Specification

| Desired Baud Rate | Divisor Used to<br>Generate 16X Clock<br>(in decimal) |
|-------------------|---|
| 50                | 3840  |
| 75                | 2560  |
| 110               | 1745  |
| 134.5             | 1428  |
| 150               | 1280  |
| 300               | 640   |
| 600               | 320   |
| 1200              | 160   |
| 1800              | 107   |
| 2000              | 96  |
| 2400              | 80  |
| 3600              | 53  |
| 4800              | 40  |
| 7200              | 27  |
| 9600              | 20  |
| 19200             | 10  |

Baud rate can be programmed by writing desired divisor into Divisor Latch in 8250 (port 28H and port 29H) parity, no. of start bit and stop bit can also be programmable by writing into line control register.

I/O Address assigned:

28H : RBR :— Receiver Buffer Register  
 28H : DLL :— Divisor Latch (least significant)  
 28H : THR :— Transmit Holding Buffer Register  
 29H : DLM :— Divisor Latch (Most significant)  
 29H : IER :— Interrupt Enable Register  
 2AH : IIR :— Interrupt Identification Register  
 2BH : LCR :— Line Control Register  
 2CH : MCR :— Modem Control Register  
 2DH : LSR :— Line Status Register  
 2EH : MSR :— Modem Status Register

RS — 232 Connector pin assignment

Pin 1 & 7 :— GND  
 2 O/P :— SOUT Serial data out  
 3 I/P :— SIN Serial data in  
 5 I/P :— CTS Clear to send  
 6 I/P :— DSR Data set Ready  
 8 I/P :— RLSD Receive line signal defect  
 4 O/P :— RTS Request to send  
 20 O/P :— DTR Data Terminal Ready

All signal names in the RS-232C standard are from the perspective of the DTE (SV 318 or SV 328), the DTE transmits on pin 2 and receives on pin 3. On the other hand the DCE (modem) transmits on pin 5 and receives on pin 2. Signal level on RS-232C data line

5V to 25V = logic 0

-5V to -25V = logic 1

All other signals are positive — True Common D-type (25 pin) connector is used in this card. The RS-232 Card should be placed in the expander (SV-601 or SV605 for communication).

© 1983 SPECTRAVIDEO INTERNATIONAL LTD.

SV 805 UM

PRINTED IN HONG KONG